

FOR YOU SAFTEY

If you smell gas:

1. Open windows
2. **DO NOT** try to light any appliance.
3. **DO NOT** use electrical switches.
4. **DO NOT** use any telephone in your building.
5. Leave the building.
6. Immediately call your local gas supplier after leaving the building. Follow gas supplier's instructions.
7. If you cannot reach your gas supplier, call the Fire Department.

⚠ WARNING



Fire Hazard

Do not store or use gasoline or other flammable vapors and liquids in the vicinity of this or any other appliance.

Some objects will catch fire or explode when placed near this heater.

Failure to follow these instructions can result in death, injury or property damage.

Reflect-O-Ray®

EDS & EHS 4

Gas fired, Low Intensity Infrared Vacuum Vented Infrared Heating Systems Installation, Operating, Maintenance and Parts Manual

⚠ WARNING



Read and understand these installation, operating and maintenance instructions thoroughly before installing or servicing this equipment. Only trained, qualified gas installation and service personnel may install or service this equipment.

Installer

Please take time to read and understand these instructions prior to any installation. Installer must give a copy of this manual to the owner.

Owner

Keep this manual in a safe place in order to provide your serviceman with the necessary information.



Combustion Research Corp.
2516 Leach Rd.
Rochester Hills, MI 48309-3555
Telephone: 248.852.3611
Fax: 248.852.9165

www.combustionresearch.com



! WARNING



FIRE OR EXPLOSION HAZARD
Can cause death, severe injury and/or property damage.

1. Read this manual carefully before installing or servicing this equipment. Improper installation, service or maintenance can cause death, injury and/or property damage.
2. Check clearances given on the outside of each burner to make sure the product is suitable for your application.
3. Installer must be a trained, experienced service technician.
4. All service must be performed only by a trained service technician or representative
5. After installation is complete, check system operation as provided in these instructions.

Combustibles: Failure to maintain the specified minimum clearances to combustibles could result in a serious fire hazard. Do not locate flammable or combustible materials within this distance. Signs must be posted near thermostat and in storage areas to specify maximum stacking height to maintain required clearances to combustibles. Do not locate in hazardous atmospheres containing flammable vapors or combustible dust.

United States: Installations in public garages or airplane hangars are permitted when in accordance with NFPA-88 (latest edition) and NFPA-409 (latest edition) Codes.

Canada: Installation in public garages and airplane hangars is permitted when in accordance with CAN/CGA B.149.1 & CAN/CGA B149.2.

Vehicles: Minimum clearances must be maintained from vehicles parked, below the heater. Ensure that adequate clearance is maintained where vehicles are in operation or being serviced.

Gas Connection: There is an expansion of the radiant pipe With each firing cycle, and this will cause the burner to move with respect to the gas line. This can cause a gas leak resulting in an unsafe condition if the gas connection is not made strictly in accordance with page 15 of these instructions.

Ignition: This appliance does not have a pilot. It is equipped with an ignition device, which automatically lights the burner. Do not try to light the burner by hand.

Mechanical Hazard - Vacuum Exhauster: High speed rotating vacuum exhauster impeller/wheel can cause severe injury. Do not operate the vacuum exhauster without impeller. Loose clothing can be drawn into unguarded inlet and entangle with impeller wheel. Keep hands and fingers away from inlet and outlet. Install exhaust duct with "bird screen" or approved vent cap on vacuum exhauster outlet.

Mechanical Hazard - Suspension: Use appropriate suspension hardware, beam clamps (rod or perforated strap) and turnbuckles at predetermined locations. The weight and normal movement of the heating system may cause support failure if the following minimum suspension requirements are not met: Distance between combination hangers must be 10-ft. (3 M) or less; chain size must be 3/0 minimum or equivalent. **DO NOT** suspend 1/4 hp and larger vacuum exhausters with chain. Failure of the suspension system and associated supports can cause death, severe injury or property damage.

NOTICE

Failure to follow these instructions can cause personal injury or property damage:

Caution must be used when running the system near combustible materials such as wood, paper, rubber, etc. Consideration should be given to partitions, storage racks, hoists, building construction, etc. Page 5 & 6 outlines minimum acceptable clearances to combustibles.

If the building has a slight negative pressure or contaminants are present in the air, an outside combustion air supply to the heaters is strongly recommended.

Do not use in an atmosphere containing halogenated hydrocarbons or other corrosive chemicals. Some compounds in the air can be drawn into the equipment and can cause an accelerated rate of corrosion of some parts of the radiant heat exchanger. The use of such chemical compounds in or near the enclosure should be avoided where a longer life of the burner, tubing and other parts is desirable.

! CAUTION

Failure to follow these instructions can cause damage to the system components:

DO NOT high-pressure test the gas piping with the burners connected. Failure to follow this procedure will exceed the pressure rating of burner gas controls and this will **require complete replacement of these parts.**

DO NOT operate a vacuum exhauster with an unrestricted inlet. Operating a vacuum exhauster when not installed on a system requires the use of a damper that is one-half closed. An unrestricted airflow will overload the motor, which can cause burnout or failure.

This heater is designed for heating nonresidential indoor spaces. These instructions, the layout drawing, local codes and ordinances, and applicable standards that apply to gas piping, electrical wiring, venting, etc. must be thoroughly understood before proceeding with the installation.

INSTALLER

PLEASE TAKE TIME TO READ AND UNDERSTAND THESE INSTRUCTIONS PRIOR TO ANY INSTALLATION. Contact your representative or the factory if you have any questions

OWNER

Retain this manual in a safe place to provide your serviceman with information if the situation arises.

TABLE OF CONTENTS

	PAGE(S)
WARNING SYMBOLS	1
STANDARDS, CERTIFICATIONS AND CODES	1 & 2
INSTALLER QUALIFICATION & RESPONSIBILITY	2
INSTALLATION NOTES	3
TUBE LENGTH REQUIREMENTS	3 & 4
VACUUM EXHAUSTER SELECTION	4
CLEARANCE TO COMBUSTIBLES	5 - 7
SYSTEM INSTALLATION	8 & 9
SEISMIC RESTRAINT SUSPENSION	10
SUSPENSION METHODS	11
REFLECTOR INSTALLATION	12 & 13
DAMPER TYPES	14
DECORATIVE GRILLE INSTALLATION	15
RADIANT TUBE WALL PENITRATION	16
CONNECTING BURNER TO RADIANT TUBE	17
GAS SUPPLY	18 – 19
COMBUSTION AIR	20
VACUUM EXHAUSTERS	21 – 23
VENTING	24 – 27
ELECTRICAL WIRING & CONTROL PANELS	28 – 29
BURNER WIRING SCHEMATICS	31
BURNER TECHNICAL DATA	32
BURNER SETUP	33
SEQUENCE OF OPERATION	34 - 36
SYSTEM SHUT DOWN & MAINTENACE	37 - 40
TROUBLE SHOOTING FLOW CHART	41 & 42
BURNER PARTS LIST	43
VACUUM EXHAUSTER PARTS LIST	44 - 47
SYSTEM ACCESSORIES AND COMPONENTS	48 - 51
WARRANTY STATEMENT AND TERMS AND CONDITIONS	53 & 54

Reflect-O-Ray® heating systems DO NOT qualify for use in explosion proof installations. Heaters SHALL NOT be used in living/sleeping areas.

©2008 COMBUSTION RESEARCH CORPORATION, INC.

All rights reserved. No part of this work covered by the copyrights hereon in may be reproduced or copied in any form or by any means - graphic, electronic, or mechanical, including photocopying, recording, taping, or information storage and retrieval systems - without written permission of COMBUSTION RESEARCH CORPORATION, Inc.

This Page Intentionally Left Blank

WARNING SYMBOLS



Warning indicates a potentially hazardous situation which, if not avoided, could result in death or injury.



Caution indicates a potentially hazardous situation which, if not avoided, could result in minor or moderate injury.



Notice indicates a potentially hazardous situation which, if not avoided, could result in property damage.

CHECKING SHIPMENT

Upon receipt of shipment, check shipment against Bill of Lading for shortages. Also check for external damage to cartons or tube bundles. Shortages and/or external damage to cartons or tubes must be noted on the Bill of Lading in the presence of delivery trucker. The delivery trucker should acknowledge any shortages or damage by initialing this "noted" Bill of Lading.

Claims for damaged material, or shortages that were not evident upon receipt of shipment must be reported to carrier and Combustion Research Corporation Sales Representatives within 72 hours.

Before starting to assemble the heater, make sure that all optional and accessory items are accounted for and are available for assembly. It is also important to verify that the correct gas burner is supplied for the gas service, i.e., natural gas burner for natural gas supply.

IMPORTANT



**IMPROPER INSTALLATION
CAN CAUSE DEATH, SEVERE
INJURY AND/OR PROPERTY
DAMAGE.**

Read and understand these installation, operating and maintenance instructions thoroughly before installing or servicing this equipment. Only trained, qualified gas installation and service personnel may install or service this equipment.

These instructions, the layout drawing, local codes and ordinances, and applicable standards such as apply to gas piping and electrical wiring must be thoroughly understood before proceeding with the installation.

TESTED UNDER STANDARDS

AMERICAN STANDARDS – Z83.20-(current standard)

CANADIAN STANDARDS – CSA 2.34 - (current standard)

GAS FIRED BROODERS - CAN 1-2.20-M85

BUILDING CODES

In the absence of local codes, the installation must conform to the latest edition of:

United States: National Fuel Gas Code, ANSI Z223.1 (NFPA 54).

Canada: CAN/CGA B149.1 and .2, Canadian Electrical Code C22.1

AIRCRAFT HANGERS

Heaters for use in aircraft hangers must be installed in accordance with;

United States: Refer to Standard for Aircraft Hangars, ANSI/NFPA 409 (latest edition).

In Canada: Refer to Standard CAN/CGA B149.1 and B149.2 and applicable Standards for Aircraft Hangars.

Basic guidelines are as follows:

1. Suspended heaters in aircraft storage or service areas shall be installed at least ten feet (10') above the upper surface of wings or engine enclosures of the highest aircraft which may be housed in the hanger. This should be measured from the bottom of the heater to the wing or engine enclosure, whichever is highest from the floor.
2. In other sections of aircraft hangers, such as shops or offices communicating with airplane storage or servicing area, heaters shall be installed in accordance with their listings and mounted not less than eight feet (8') above the floor.
3. Heaters installed in aircraft hangers shall be located so as not to be subject to injury by aircraft, cranes, moveable scaffolding or other objects. Provisions shall be made to ensure accessibility to suspended heaters for recurrent maintenance purposes.

PUBLIC GARAGES

Heaters for use in public garages must be installed in accordance with:

United States: Standard for Parking Structures NFPA 88A (latest edition) or the Code for Motor Fuel Dispensing Facilities and Repair Garages NFPA 30A (latest edition).

Canada: Refer to CAN/CGA B149.1 and B149.2: Installation Codes for Gas Burning Appliances and applicable Standards for Public Garages.:

Basic guidelines are as follows:

1. Heaters shall be installed in accordance with their listings and not be mounted less than eight feet (8') above the floor. Minimum clearances to combustibles must be maintained from vehicles parked below the heater.
2. When installed over hoists, clearance to combustible material must be maintained from upper most point of the hoist, or provided as insulating or reflective barrier on the hoist (consult representative or factory for guidance).

ELECTRICAL GROUNDING

The burner and blower unit must be electrically grounded in accordance with the following codes:

United States: Refer to National Electrical Code®, ANSI/NFPA 70 (latest edition). Wiring must conform to the latest edition of National Electrical Code®, local ordinances, and any special diagrams furnished.

Canada: Refer to Canadian Electrical Code CSA C22.1 Part 1 (latest edition).

GAS INPUT LINES

The method of pipe sizing must conform to the U.S. National Standards: ANSI Z223.1 (current standard) National Fuel Gas Code or CAN 1-B149.1 Installation Code, and should be installed in accordance with all National and Local Codes and ordinances.

CLEARANCES AND ACCESSIBILITY

Inlet air assemblies are to be installed with the air opening pointing toward the ground to protect against rain and snow. Inlet is provided with a bird screen. Adequate clearance must be provided around the inlet air assembly opening to provide an unobstructed entry for the combustion air. The air should be taken from outside the building. Clearances must be sufficient to provide accessibility for servicing. The air inlets must be a minimum of six feet (6') from the exhaust port.

AGRICULTURAL INSTALLATIONS

In agricultural installations *Reflect-O-Ray*® heating systems must be installed as vented systems only.

HAZARDOUS LOCATIONS

Where there is the possibility of exposure to combustible airborne materials or vapor, consult the local Fire Marshal, the fire insurance carrier, or other authorities for approval of the proposed installation. ***Reflect-O-Ray*® heating systems DO NOT qualify for use in explosion proof installations.**

INSTALLER QUALIFICATIONS

Only firms or individuals qualified to perform work in accordance with the applicable specifications should be engaged to install a *Reflect-O-Ray*® system. Consult local Building Inspectors, Fire Marshals, or the local applicable Combustion Research Corporation representative for guidance.

INSTALLER RESPONSIBILITY

Reflect-O-Ray® systems are installed on the basis of information given in a layout drawing. Together with these instructions and the cited codes and regulations comprise the information needed to complete the installation. The installer must furnish all needed material that is not furnished as standard *Reflect-O-Ray*® equipment, and it is his responsibility to see that such materials, as well as the installation methods he uses result in a job that is workman like and in keeping with all applicable codes.

In storage areas where stacking of materials may occur, the installer must provide signs that specify the maximum stacking height so as to maintain the required clearance to combustibles.

GENERAL CONSIDERATIONS

Combustion Research Corporation Factory Representatives are experienced in the application of this equipment and can be called on for suggestions about installation which can give the owner of the building a more satisfactory and economical installation.

When installing the *Reflect-O-Ray*® system, take maximum advantage of the building upper structure, beams, Joists, purlins etc. from which to suspend the system. Mount units at minimum height for ease of installation and maintenance but of specified height to fully utilize the building.

The general lay out of the *Reflect-O-Ray*® heating system has been established by the engineering drawing. The *Reflect-O-Ray*® heaters are used to heat building structures as well as localized areas that would include doors, loading docks and isolated workstations throughout the building. The location of the *Reflect-O-Ray*® heaters should be such that the area is covered uniformly, in that the heat is positioned on the perimeter or to each side of the area to be heated, rather than directly overhead. This will give a better comfort condition for workers who would be in these areas. Consult with your representative or the factory for additional guidance in designing the optimum layout for your project.

Reflect-O-Ray® is a suspended system, which requires that consideration be given to the factors that determine its stability, flexibility, safety, and satisfactory operation. Before installation, the contractor should inspect the building along with the owner (or engineer) responsible for the building to check on the use of the building. Inspection of the building including the use of floor space for storage and height of materials stored in the building must be noted so that there are no problems with clearances to combustibles. Particular care should be taken over doors and high objects such as busses, trucks, cranes, car lifts, etc. Whenever possible use side wall penetrations for combustion air inlets to burners and exhaust venting.

DO -

- **Maintain specified clearances to combustibles, and to heat sensitive material, equipment, and workstations.**
- **Provide approved heat radiation shielding or barriers if needed. Refer to the National Fuel Gas Code for guidance.**
- **Provide access for general servicing; provide easy access for complete removal of burner and blower.**
- **Familiarize yourself with local and national codes. Develop a planned installation procedure, which will conserve material and labor on the job. Check to see that all material and equipment is on the job before starting installation. Be sure to accommodate thermal expansion of the hot tube.**
- **Use the gas connector ONLY as shown in the instructions.**
- **Provide end clearance so tubing won't expand and touch a wall or a structural member.**

INSTALLATION NOTES

A. GENERAL INSTALLATION LAYOUT

1. Height from floor - 8' to 30' (refer to chart for recommended minimum mounting heights). There are no restrictions on the mounting height of the equipment providing the design is based on the full heat loss of the building. Consideration must be given to the building heat loss so as to cover the air infiltration and/or the mechanical ventilation of the building. For serviceability and optimum performance the system should be mounted with careful consideration to the use of the building.

B. RADIANT TUBE ELEMENT LENGTHS FOR STANDARD (EDS 4) SYSTEMS.

1. To dissipate maximum heat and avoid continuous condensation in the radiant tube elements, each burner will be provided with the minimum or maximum tube lengths as outlined in the following chart. A heavy walled 16 gauge aluminized steel tube (9'-9") long is used adjacent to each burner. **NOTE: Burners with inputs of 180,000 Btu/hr and higher use one 16 gauge ALUMATHERM tube and one 16 gauge ALUMINIZED STEEL TUBE (swaged one end).** The remainder of the radiant tubing shall be of spiral wound aluminized steel tube. Each single flow of radiant tube shall incorporate an adjustable damper for regulating burner airflow.

2. A multiple burner system consists of two or more burners. Refer to the following charts for radiant tube lengths and elbow and tee placement.

C. RADIANT TUBE ELEMENT LENGTHS FOR HIGH OUTPUT (EHS 4) SYSTEMS.

1. To dissipate maximum heat and avoid continuous condensation in the radiant tube elements, each burner will be provided with the minimum tube lengths as outlined in the following chart. A heavy walled 16-gauge aluminized steel tube 9'-9" long is used adjacent to each burner. On 180,000 Btu and higher units, a 10' long 16-gauge alumatherm steel tube is used just downstream of the burner and the next tube is a 9'-9" long 16-gauge aluminized steel tube. The remainder of the radiant tubing shall be of spiral wound aluminized steel tube. Tee's must be installed after any turbulator tube. Each single flow of radiant tube shall incorporate an adjustable damper for regulating burner airflow. **NOTE:** The radiant tubes for the Reflect-O-Ray® EHS 4 systems are heat treated for optimum heat transfer

DESIGN TUBE LENGTH REQUIREMENTS FOR OPTIMUM EFFICIENCIES

The dimensions in the table listed below are basic guidelines used in the design of the *Reflect-O-Ray® EDS 4 & EHS 4* systems. Every effort should be made to hold the dimensions given on the layout drawing. The factory should verify any deviations from the layout drawing or for alternate and/or customized layouts.

Burner	BTU/hr Input	Rec. Min. Mounting Height ft. (M)	EDS 4 Systems Standard Output		EHS 4 Systems Hi-Output Systems		Min. Distance From Burner to Elbow ft. (M)	Min. Distance From Burner to Damper or Tee /Ft. (M)
			Min. ft. (M)	Max. ft. (M)	Min. ft. (M)	Max. ft. (M)		
08040.NG/LP	40,000	8	30	50	20	45	10	10
08045.NG/LP	45,000	8	30	60	20	45	10	10
08050.NG/LP	50,000	8	40	60	25	50	10	15
08055.NG/LP	55,000	10	40	60	25	50	10	15
08060.NG/LP	60,000	10	40	60	30	50	10	20
08065.NG/LP	65,000	10	40	60	30	60	10	20
08070.NG/LP	70,000	10	50	70	30	60	10	20
08075.NG/LP	75,000	10	50	70	30	60	10	20
08080.NG/LP	80,000	12	50	70	30	70	15	25
08085.NG/LP	85,000	12	50	70	40	70	15	25
08090.NG/LP	90,000	12	50	70	40	70	15	25
08095.NG/LP	95,000	12	60	80	40	70	15	25
08100.NG/LP	100,000	12	60	80	40	70	15	25
08105.NG/LP	105,000	13	60	80	40	80	15	25
08110.NG/LP	110,000	13	60	80	40	80	15	25
08115.NG/LP	115,000	13	60	80	40	80	15	25
08120.NG/LP	120,000	13	70	90	40	80	15	30
08125.NG/LP	125,000	14	70	90	40	80	15	30
08130.NG/LP	130,000	14	70	90	50	80	20	30
08135.NG/LP	135,000	14	70	90	50	80	20	30

Burner	BTU/hr Input	Rec. Min. Mounting Height ft. (M)	EDS 4 Systems Standard Output		EHS 4 Systems Hi-Output Systems		Min. Distance From Burner to Elbow ft. (M)	Min. Distance From Burner to Damper or Tee /Ft. (M)
			Min. ft. (M)	Max. ft. (M)	Min. ft. (M)	Max. ft. (M)		
08140.NG/LP	140,000	14	70	100	50	80	20	30
08145.NG/LP	145,000	14	70	100	50	90	20	30
08150.NG/LP	150,000	15	70	100	50	90	20	40
08155.NG/LP	155,000	15	70	100	50	90	20	40
08160.NG/LP	160,000	15	70	100	50	90	20	40
08165.NG/LP	165,000	15	70	100	50	90	20	40
08170.NG/LP	170,000	16	70	110	50	90	20	40
08175.NG/LP	175,000	16	80	110	50	90	20	40
08180.NG/LP	180,000	16	80	110	50	90	20	40
08185.NG/LP	185,000	16	80	110	50	90	20	40
08190.NG/LP	190,000	17	80	110	50	90	20	40
08195.NG/LP	195,000	17	80	110	50	90	20	40
08200.NG/LP	200,000	18	90	120	50	90	25	40
08205.NG/LP	205,000	18	90	120	60	90	25	40
08210.NG/LP	210,000	18	90	120	60	90	25	40
08215.NG/LP	215,000	19	90	120	60	90	25	40
08220.NG/LP	220,000	19	90	120	60	100	25	40
08225.NG/LP	225,000	20	90	120	60	100	25	40
08230.NG/LP	230,000	20	90	120	60	100	30	40
08235.NG/LP	235,000	20	90	130	60	100	30	40
08240.NG/LP	240,000	22	90	130	60	100	30	40
08245.NG/LP	245,000	22	90	140	60	100	30	40
08250.NG/LP	250,000	22	90	140	60	100	30	40
08245.NG/LP	245,000	22	90	140	60	100	30	40
08250.NG/LP	250,000	22	90	140	60	100	30	40

VACUUM EXHAUSTER SELECTION

Recommended Maximum Number of Burners Per Vacuum Exhauster

(Note: The factory must be consulted for any deviations to the basic design criteria listed below)

BURNER ASSEMBLIES (NG or LP)

Vacuum Exhauster	08040- 08075	08080 - 08100	08105 - 08145	08150 - 08195	08200 - 08250
0402.040	8	6	6	4	4
0401.040	8	6	4	3	3
0201.040	4	3	2	2	2
0101.040	2	1	1	1	1
0103.040	2	1	1	1	1
0102.040	2	1	DNA	DNA	DNA

Burner inputs may be mixed with each system (vacuum exhauster). The total of all combined burner BTU inputs, serviced by a single vacuum exhauster, shall not exceed the following:

Vacuum Exhauster	Btu/hr Input
0402.040	900,000
0401.040	675,000
0201.040	450,000

Vacuum Exhauster	Btu/hr Input
0101.040	250,000
0103.040	250,000
0102.040	100,000

CLEARANCE TO COMBUSTIBLES

! WARNING



Placement of explosive objects, flammable objects, liquids and vapors close to the heater may result in fire, explosion, death and serious injury or property damage. Do not store or use explosive objects, liquids and vapor in the vicinity the heater.

In all situations the clearance to combustibles must be maintained. Failure to observe clearances to combustibles will result in death, serious injury, or property damage. **In storage areas where stacking of materials may occur, the installer must provide signs, which specify the maximum stacking height so as to maintain the required clearance to combustibles.** Minimum clearances must be maintained from vehicles parked, below the heater. Ensure that

adequate clearance is maintained where vehicles are in operation or being serviced. Consideration must be given when running the radiant tube next to wood, paper, storage racks, hoists, building construction, etc. For building personnel safety, it is recommended that the system not be mounted lower than 9' from the floor unless fitted with protective screens. The following illustrations and information give minimum acceptable clearance to combustibles.

Horizontal Reflector

	MODEL	A	B	C	D
	08040 - 08055	4	41	12	12
	08060 - 08075	4	50	24	24
	08080 - 08100	4	60	29	29
	08105 - 08125	4	76	34	34
	08130 - 08150	4	83	38	38
	08155 - 08175	6	85	40	40
	08180 - 08200	6	91	44	44
	08205 - 08225	8	96	46	46
	08230 - 08250	8	100	51	51
08040 – 08175 “B,C &D” Clearances can be reduced by 50% 25' downstream of burner 08180 – 08250 “B,C &D” Clearances can be reduced by 50% 35' downstream of burner					

Angled Reflector - Max 45°

	MODEL	A	B	C	D
	08040 - 08055	6	41	4	36
	08060 - 08075	6	45	4	40
	08080 - 08100	6	66	4	54
	08105 - 08125	6	76	4	66
	08130 - 08150	6	86	6	73
	08155 - 08175	6	89	6	77
	08180 - 08200	12	94	9	81
	08205 - 08225	12	96	12	88
	08230 - 08250	12	100	12	92
08040 – 08175 “B &D” Clearances can be reduced by 50% 25' downstream of burner 08180 – 08250 “B &D” Clearances can be reduced by 50% 35' downstream of burner					

One Side Shield Reflector

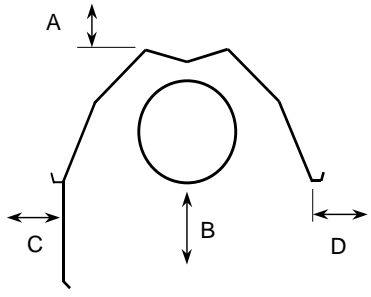
	MODEL	A	B	C	D
	08040 - 08055	4	45	6	34
	08060 - 08075	4	45	6	34
	08080 - 08100	4	72	6	42
	08105 - 08125	4	72	6	45
	08130 - 08150	4	86	6	62
	08155 - 08175	6	89	8	68
	08180 - 08200	8	93	8	72
	08205 - 08225	8	93	12	72
	08230 - 08250	8	104	12	80
08040 – 08175 “B & D” Clearances can be reduced by 50% 25’ downstream of burner 08180 – 08250 “B & D” Clearances can be reduced by 50% 35’ downstream of burner					

Two Side Shield Reflectors

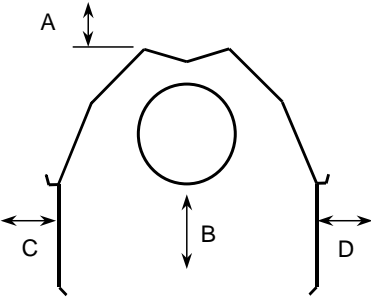
	MODEL	A	B	C	D
	08040 - 08055	4	47	12	12
	08060 - 08075	4	62	16	16
	08080 - 08100	4	74	22	22
	08105 - 08125	4	81	26	26
	08130 - 08150	4	87	30	30
	08155 - 08175	4	90	32	32
	08180 - 08200	4	94	32	32
	08205 - 08225	8	98	36	36
	08230 - 08250	8	107	39	39
08040 – 08175 “B” Clearances can be reduced by 50% 25’ downstream of burner 08180 – 08250 “B” Clearances can be reduced by 50% 35’ downstream of burner					

Reflector Mounted Above 2-Foot Wide Decorative Grille

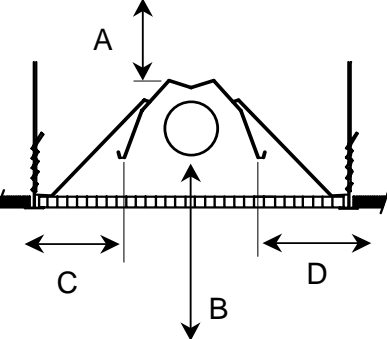
	MODEL	A	B	C	D
	08040 - 08055	4	41	12	12
	08060 - 08075	4	50	24	24
	08080 - 08100	4	60	29	29
	08105 - 08125	4	76	34	34
	08130 - 08150	4	83	38	38
	08155 - 08175	6	85	40	40
	08180 - 08200	6	91	44	44
	08205 - 08225	8	96	46	46
	08230 - 08250	8	100	51	51
08040 – 08175 “B,C & D” Clearances can be reduced by 50% 25’ downstream of burner 08180 – 08250 “B,C & D” Clearances can be reduced by 50% 35’ downstream of burner					

“U” BEND END CLEARANCE

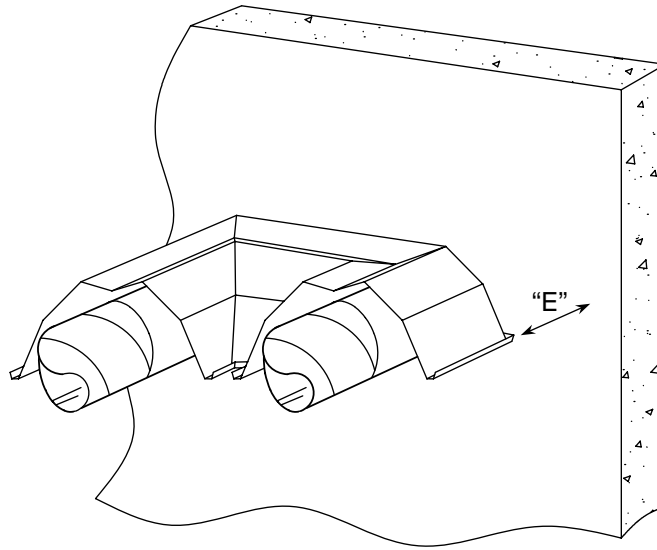

Model No.	“E” “U” Bend With Reflector Installed As Shown	Exposed “U” Bend Without Reflector. Distance Measured From Edge of Radiant Tube
08040 – 08060	8”	12”
08065 – 08100	12”	18”
08105 - 08175	18”	27”
08180 – 08250	25”	36”

UN-VENTED CLEARANCE

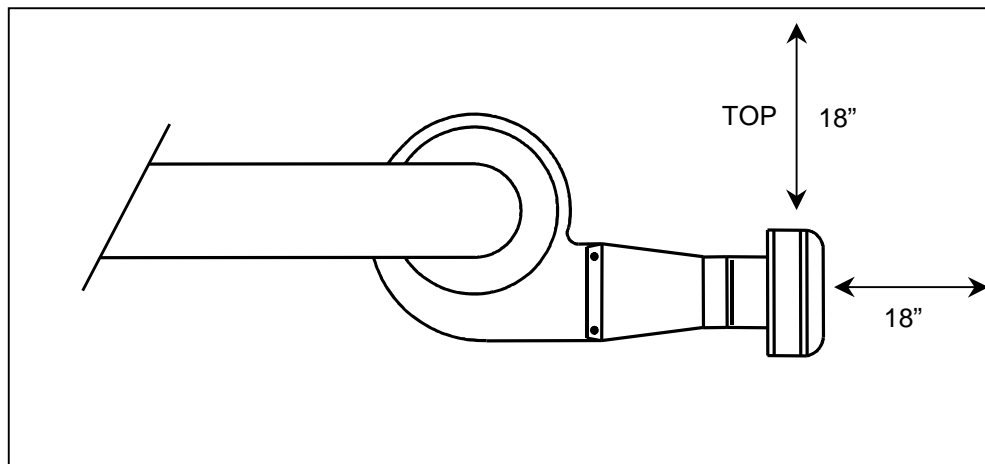

SYSTEM INSTALLATION

! WARNING

COLLAPSE, FIRE AND EXPLOSION HAZARD



Improper suspension of the tube heater may result in collapse and being crushed. Always suspend from a permanent and secure part of the building structure that can evenly support the total force and weight of entire the heating system.

Failure to maintain minimum clearance to combustibles may result in fire and/or explosion, property damage, serious injury or death. Always maintain minimum clearances and post clearance signs where needed.

Combustion Research Corporation recommends that *Reflect-O-Ray® EDS 4® & EHS 4®* systems are hung by means of chain. **DO NOT STRETCH OR INSTALL CHAIN OTHER THAN IN A VERTICAL FASHION WHEN INITIALLY INSTALLED (BURNER NOT FIRING).**

! WARNING

DO NOT SUSPEND 1/4 HP AND LARGER VACUUM EXHAUSTER BY CHAIN - USE THREADED ROD, ANGLE IRON, ETC.

If chain is not supplied by Combustion Research Corporation, furnish a chain with a minimum 90 lb. workload (trade size #3 or larger).

CAUTION: This infrared tube system will expand and contract upon each call for heat and allowances must be made to accommodate this expansion.

Provisions must be made to limit lateral movement when systems are installed in site conditions where open doors may create a wind condition. See page 10 for details.

SUSPENSION COMPONENTS - Sub Assembly and Installation

1. Using the system layout, beginning at the vacuum exhaustor position, determine location of suspension points of system in relation to building structure, paying close attention to dimensional limits as shown on page 8.
2. Determine suspension requirements for chain, wire rope, beam clamps, etc. with the type of mounting hardware as illustrated. Secure appropriate of each item before starting installation. Suspension hardware may not be furnished with this system.
3. If any suspension supports are to be anchored in cement, drill and insert Acherman-Johnson stud anchors

(or equivalent) as required. DO NOT install anchors in existing cracks or joints.

4. Determine suspension chain lengths and proceed to cut and pre assemble suspension components.

NOTE: Each *Reflect-O-Ray® EDS 4 & EHS 4* burner assembly is equipped with a suspension point. Adjust as required to keep the burner assembly level and square to the radiant tubing.

5. Install beam clamps, eyebolts, etc. at predetermined suspension locations - refer to the installation layout and the illustration on page 10 of this manual for guidance.

IMPORTANT NOTE: If wind or sever air movement can be encountered in the building (such as found in airplane hangers where opposing doors are simultaneously open) or if your area is prone to seismic activity, additional support of the radiant tube and reflector network will be required. See page 11 for details

RADIANT TUBE INSTALLATION

The *Reflect-O-Ray® EDS 4 & EHS 4* radiant heating system is sealed system. Therefore the heat radiant tubing installation must be adhered to as outlined in this manual for optimum performance as designed.

RECOMMENDED HANGER LOCATIONS

For 40K to 175K input systems, the first 10' section of radiant tube (0404.AS.16 or 0404.16.HT) after the burner should be supported and hung with 3 combination hangers. For 180K to 250K input systems, the first 20' of radiant tube (0404.AT.16 & 0404.16.AS) after the burner should be supported and hung with 5 combination hangers

NOTE – THE WELD SEAM ON THIS FIRST (AND SECOND IF PROVIDED) SECTION OF TUBE MUST BE POSITIONED SO THAT IT IS ON THE BOTTOM OF THE TUBE WHEN INSTALLED.

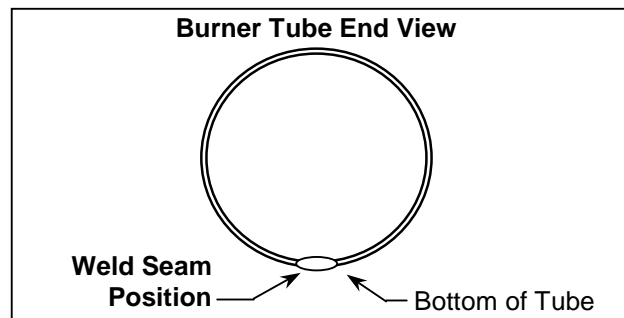

The first hanger should be located approximately 5" from the burner and the next two combination hangers shall be hung on approximately 56" centers. The rest of the system combination hangers may be hung on approximately 9'-10" centers with intermediate reflector supports placed halfway between hangers. Each reflector should be supported at two points, either with two combination hangers or with one combination hanger and an intermediate support

NOTE: When a vertical rise of tube is necessary, use a combination hanger (P.N. 0464.00) at both the lower horizontal run hanger and at the upper horizontal run. If the vertical run exceeds ten feet (10') a midway support must be installed. This support may be secured to a wall, beam or fabricated support. It is recommended that the vertical run not exceed twenty-five feet (25').

Radiant Tube Sub-Assembly:

CAUTION

CUT HAZARD - SHARP EDGES.



Wear protective gloves when installing and handling and cutting radiant tubes. Failure to follow these instructions will result in personal injury.

It is recommended that a maximum of twenty-foot lengths of radiant tube and possibly an elbow be assembled on the floor before raising into position.

Experience has shown that it is best to start laying out the system from the exhauster end, although this is not a requirement. Avoid small segments that cannot be supported properly according to the instructions in this manual.

1. Apply sealer sparingly from the tube furnished to the outside of the heat tube coupler, elbows, and other fittings.

NOTE: Failure to use sealer can result in loss of vacuum.

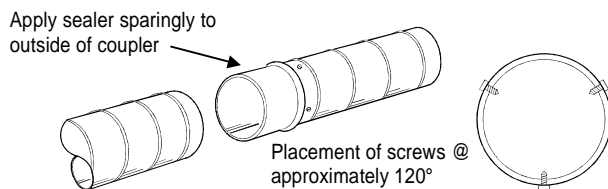

2. Secure joint with sheet metal screws to provide a mechanical joint rather than rely on friction. Use damp cloth to remove excess sealer. Heat tube and fitting assembly ends are designed for minimum clearance and tight fitting to minimize air in infiltration.

3. Insert coupler inside tube section. Be sure the radiant tube is butted up tightly against the stop rim in the middle of the coupler. Note: Tolerances are closely controlled at this point to insure as tight a joint as possible. At this point make sure that radiant tube sections to be joined are straight and in line.
4. Attach combination hanger (0464.00) to the radiant tube at dimensional support locations as outlined in this manual. Combination hangers should be positioned so that the locking loop / 45° suspension point, face the same direction. Combination hanger's (0464.00) shall be positioned at all elbows and tee's so as to provide support for the adjoining reflector.
5. Position the intermediate reflector supports (0465 .00) between the combination hangers illustrated below.
6. Using two or more men, raise the length of pre assembled tube sections up to suspension height, and using "S" hooks or turnbuckles attach tube hangers to suspension hardware.
7. Check to be sure all suspension hardware, chain, wire rope, etc., is hanging straight. Reposition hangers where necessary until suspension is straight.
8. Adjust suspension length until heat tube is straight and in line. If possible, heat tube should be parallel with floor.
9. Proceed in manner described above to complete hanging the remainder of the radiant tubes as described and detailed in this owner's manual and the layout drawing.

NOTE: Review system layout carefully before any cutting radiant tube. If cuts are not made where shown, radiant tube lengths may be short and require additional tube couplers to complete the project.

When cutting radiant tubes, deburr them with a file to remove sharp edges and facilitate easier assembly with the couplers.

10. Make final check to be sure heat tube is straight and in line before installing reflectors as illustrated on page 12 and 13.

40k to 175k Inputs

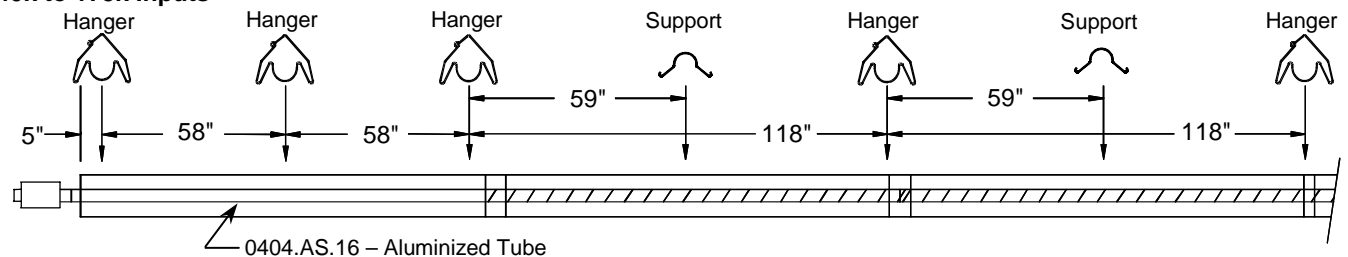

180k to 250k Inputs

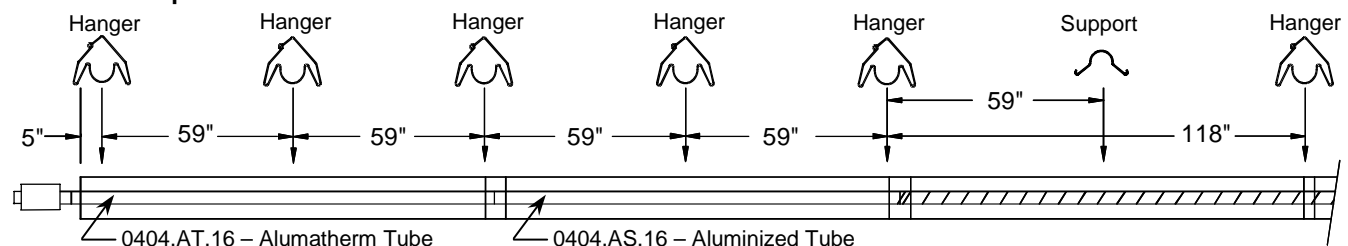

SUSPENSION METHODS

System shall be suspended by chain (trade size #3 or larger), wire rope, etc., minimum workload of 90 Lbs. All suspension hardware must be corrosion resistant. For fine adjustment turnbuckles may be used.

NOTES:

- DO NOT HANG ¼ HP AND LARGER VACUUM EXHAUSTER WITH CHAIN – USE THREADED ROD.
- SECURE TURNBUCKLES WITH A WIRE OR JAM NUT SO THAT THEY WILL NOT UNWIND OR UNSCREW.
- CRIMP "S" HOOKS CLOSED BEFORE LEAVING JOB.
- LISTED MATERIALS ARE MINIMUM REQUIRED, USE EQUIVALENT OR BETTER MATERIALS

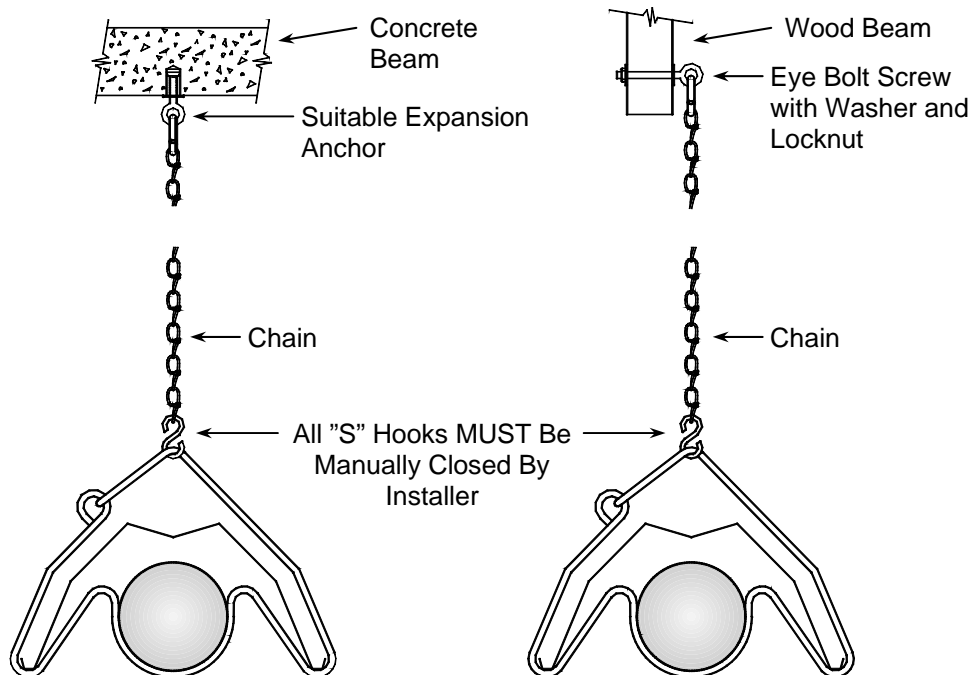
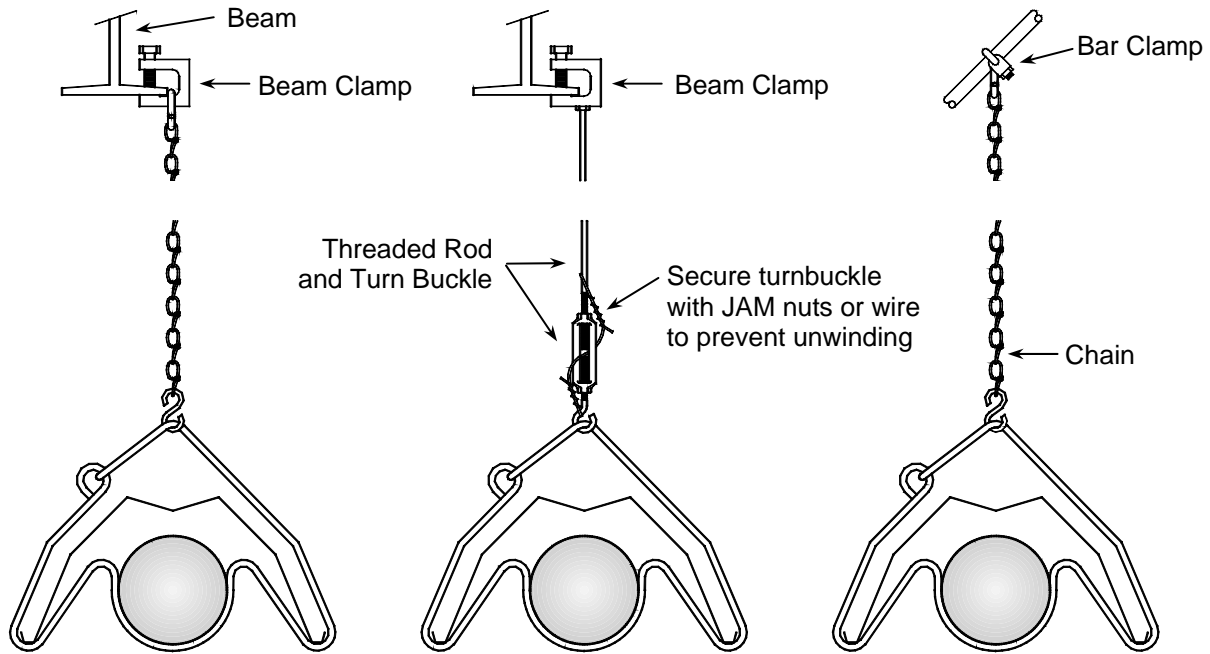

SEISMIC RESTRAINT SUSPENSION METHODS

For standard seismic restraint such as earthquake prone areas, install seismic restraint chain or cable as shown below. If high winds can be encountered in the building, such as found in airplane hangers where opposing doors are simultaneously open, or system is installed near or

below the door opening, additional support of the radiant tube and reflector network will be required. See the "Seismic Suspension For High Wind or Outdoor Applications" below for details. If there are any questions regarding what method is best suited for your application consult your sales representative or contact the factory.

STANDARD SEISMIC SUSPENSION

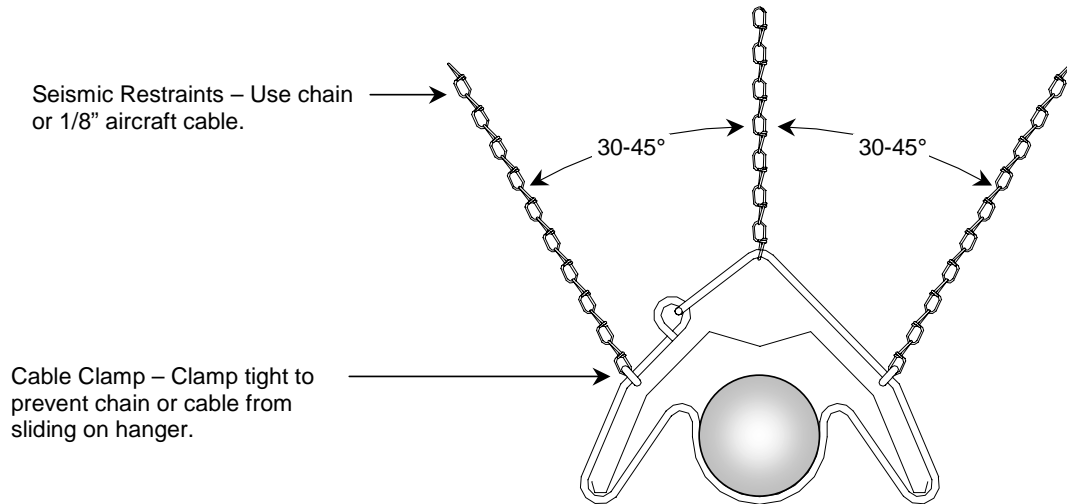

SEISMIC SUSPENSION FOR HIGH WIND OR OUT DOOR APPLICATIONS

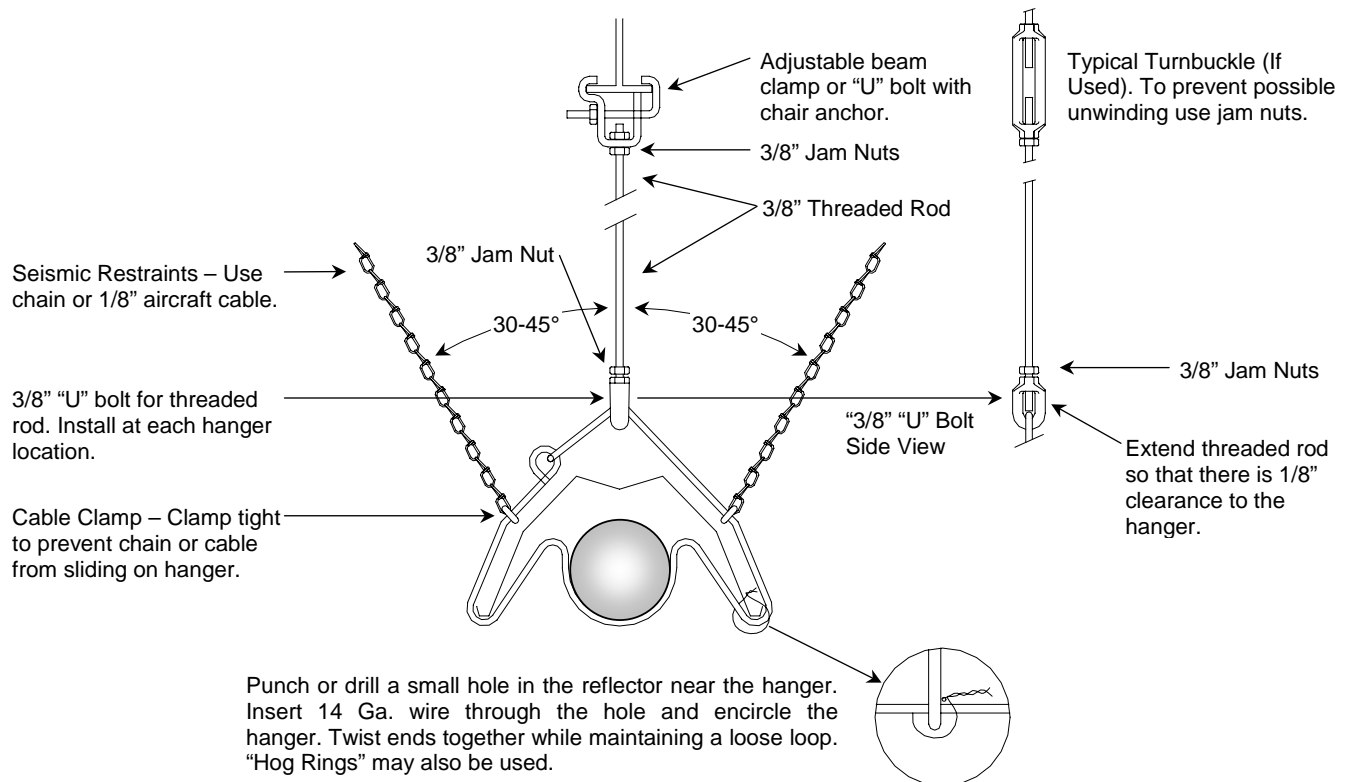

REFLECTOR INSTALLATION

CAUTION

CUT HAZARD - SHARP EDGES.



Wear protective gloves when installing and handling and cutting reflectors. Failure to follow these instructions will result in personal injury.

Heat tube combination hangers are an integral part of the reflector support system. Improperly installed heat tube hangers will distort reflectors and result in an undesirable appearance of the entire system.

Check to be sure all combination hangers and intermediate supports are hanging straight. Tubes must be straight and in line before installing reflectors.

Install reflector elbows and "tees" where required.

1. Starting from burner slide reflector through tube hanger until end stops against drawband coupler. Nearest the burner, attach reflector end cap to with 4 sheet metal screws.
2. Adjust position of reflector supports so that reflector is held level and parallel with heat tube. Where possible, position one support at overlapped ends of reflectors.
3. Using same procedure, continue to install reflector sections until entire system is complete. Make sure each reflector section is overlapped a minimum of 1 -2" and secured as outlined on page 13.
4. When last section of reflector has been installed, inspect heat tube and reflector assembly as follows:
 - a. Check to be sure all heat tubes are straight and in line. Adjust suspension when necessary.
 - b. Make sure all radiant tube joints are properly aligned, sealed, and secured.
 - c. Check all heat tube suspension points, clamps, turnbuckles, lock nuts, etc. are in place and tight. All suspension chain should be hanging straight down.
 - d. Check all reflector joints for minimum 1 - 2" overlap.
 - e. Overlapped joints are secured with sheet metal screws. Make sure expansion joint is in every straight run - see page 13.
 - f. Check all reflector hangers and supports for location and make sure reflectors are straight and in line.
 - g. Make sure all combination hanger hooks are closed.

PERIMETER MOUNTING

In areas of high heat loss such as doorways and the perimeter of some buildings, it may be desirable to install the reflectors so that heat is concentrated and directed to a specific area rather than straight down. Two options are available to accomplish this, 1) install side shields or 2) angle mount the reflector.

SIDE SHIELD INSTALLATION

Optional side shield reflectors (PN 0366.00) may be installed on either side or both sides of the reflector. The 10-ft. (3 m) long side shields should line up with a reflector and have identical overlap and expansion joints.

1. Position the side shield reflector next to the reflector, and mark the areas where relief notches must be cut.
2. Cut the appropriate relief notches as noted.
3. Secure the side shield to the reflector with #8 x 3/8" sheet metal screws. The screws should be used approximately every 36" (91 cm).
4. Install the side shield supports (P/N 0366.0050) every five feet (5')
5. An expansion joint must be used in each straight run. This expansion joint should match the location of the expansion joint for the reflectors. All overlap areas should also match the reflector overlap.

In applications where excessive air movement is encountered, such as open doors and the like, the Side Shields should be fastened together with 2 sheet metal screws at each overlap joint. **NOTE: DO NOT** screw the expansion joints together.

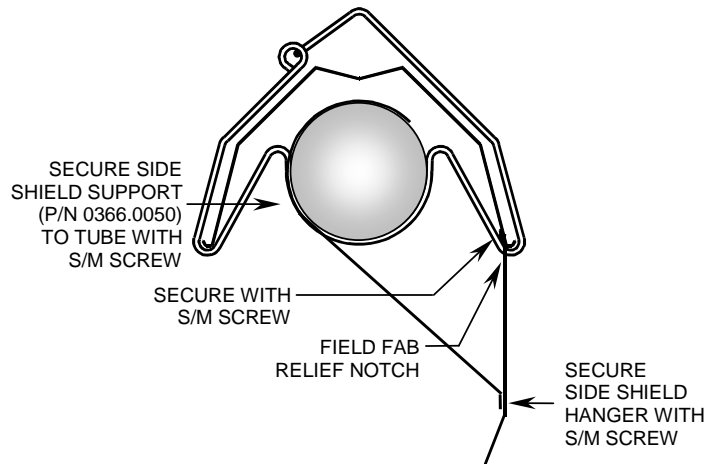

REFLECTOR ANGLE MOUNTING

The combination hangers are designed so that the suspension hardware can be attached either in the center or to one side that will position the tube and reflector assembly up to a maximum 45° angle. This angle can be reduced if required by use of a tie strap.

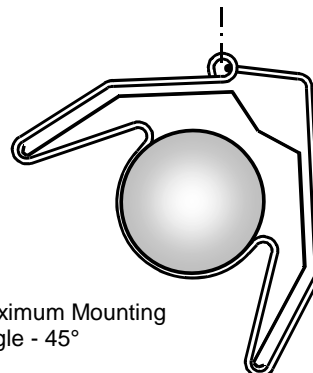

Maximum Mounting Angle - 45°

REFLECTOR ELBOW CONNECTION

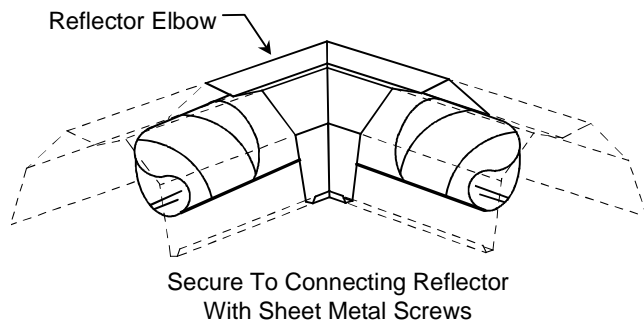

REFLECTOR TEE CONNECTION

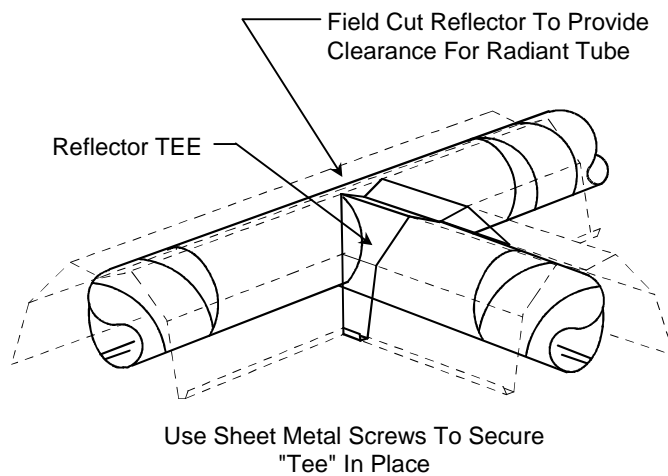

For "X" fittings (PN 0404.AS.X) use the same technique shown, cutting and another relief hole on the opposite side of the reflector and installing a second reflector tee.

TYPICAL REFLECTOR LAYOUT WITH EXPANSION JOINTS

An expansion joint consists of a reflector overlap without being secured together. This allows for freedom of movement during heat up and cool down. Expansion joints are to be placed at approximately the center of each straight run of reflectors with a maximum of three (3) reflectors connected together. Additional expansion joints in each straight run may be necessary.

All other reflector joints, reflector elbows and reflector tee's should be overlapped 1 - 2" and sheet metal screwed together, DO NOT position an expansion joint at an elbow or tee.

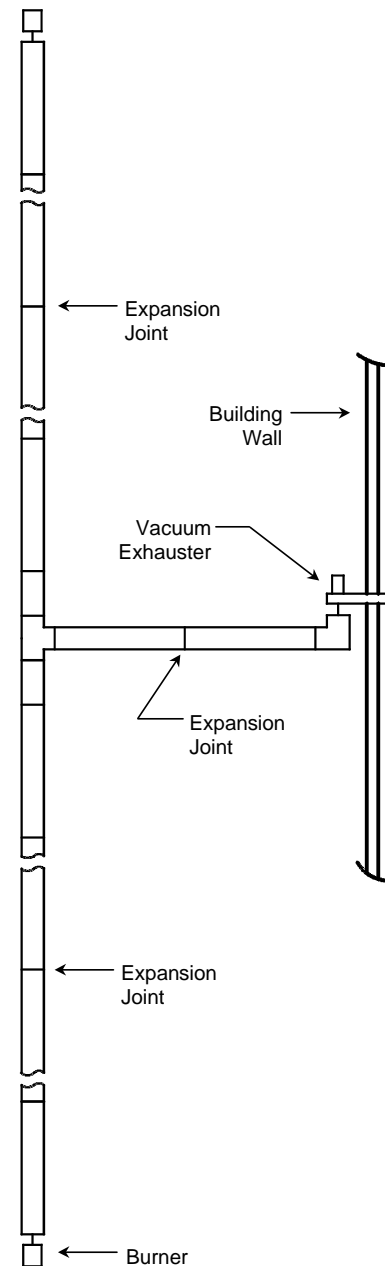

DAMPER TYPES

Damper assemblies are to be installed as per layout drawing. Each burner flow must be equipped with a damper assembly so that accurate vacuum settings can be made.

NOTE: Install all damper handles so that they face downward. The damper handle can be rotated by removing the two nuts, which hold the blade, and setting plate in place. Rotate 180° and reassemble - take care so as not to "strip out" handle. When turning the damper handle the retaining spud on the opposite side should rotate simultaneously.

0407.AS.B - Damper TEE

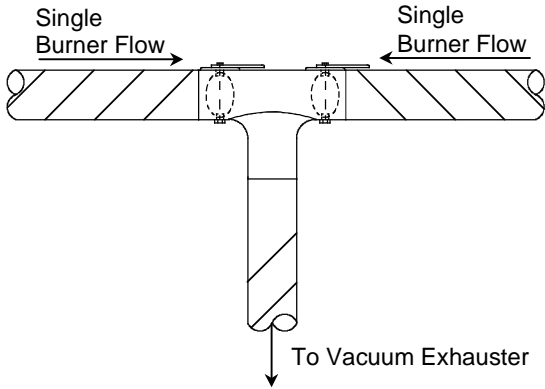

0407.AS.C - Damper

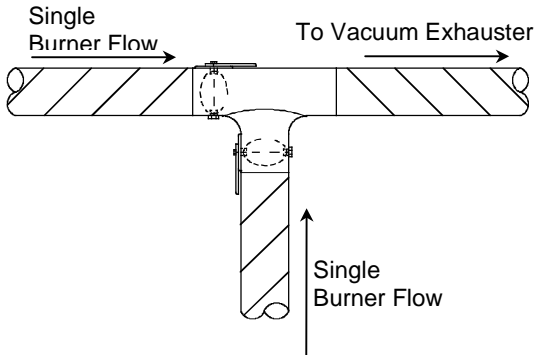

0441.00 DAMPER ASSEMBLY

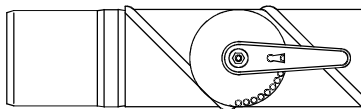

Install Handle On Side Or Bottom Of Tube
(Position locating holes as shown)

NOTE: 0441.00 damper assembly for use with single burner systems and when DAMPER TEE'S are not practical.

0407.AS.XB - "X" Fitting With Dampers

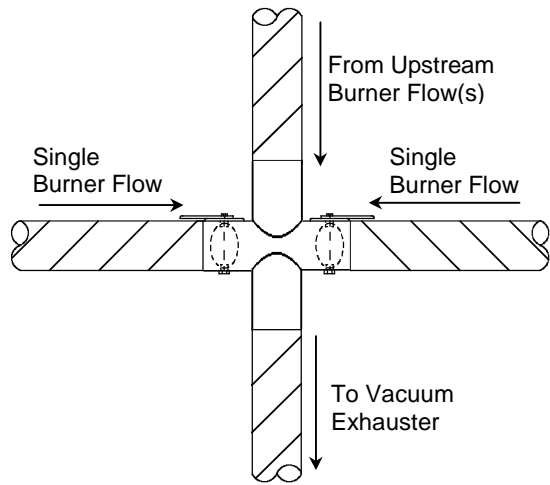

0407.AS.XC - "X" Fitting With Dampers

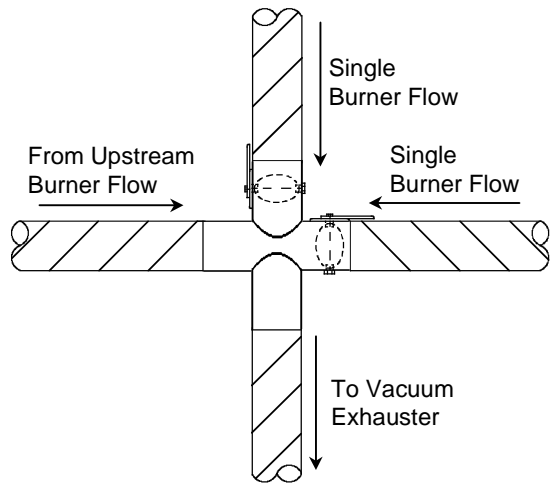

DECORATIVE GRILLE INSTALLATION

⚠ CAUTION

CUT HAZARD - SHARP EDGES.



Wear protective gloves when installing and handling aluminum decorative grille and side shields. Failure to follow these instructions will result in personal injury.

When installing the heating system above a suspended ceiling, decorative grille must be used directly beneath the radiant tube system. The use of regular ceiling tiles directly beneath the radiant tube will create an unsafe condition.

The decorative grille provides an attractive finish to the system when installed over a suspended ceiling. The aluminum Decorative Grille (PN 0369.00) comes in standard 2 ft. x 4 ft. (60 cm x 120 cm) sections and is installed in place of the ceiling tile. The decorative grill should extend completely under all of the radiant tube as well as the burner assembly.

The radiant tube is suspended in normal fashion, preferably centered over the decorative grille. The radiant tube must be installed, as shown below, with a minimum distance from the radiant tube to the decorative grille of 6" (15.2 cm) to a maximum of 10" (25.4 cm).

"T" bar heat shields (PN 0369.21) must be installed over ceiling "T" frame members that pass underneath the radiant tube. The Decorative Grille Side Shield reflector (PN 0369.11) is available in 10-ft. (3 m) lengths. Lay the side shield along the standard reflector and cut suitable notches for the reflector hangers and "T" bar sections. As sharp edges can be encountered when working the aluminum decorative grille and side shields, gloves should be worn.

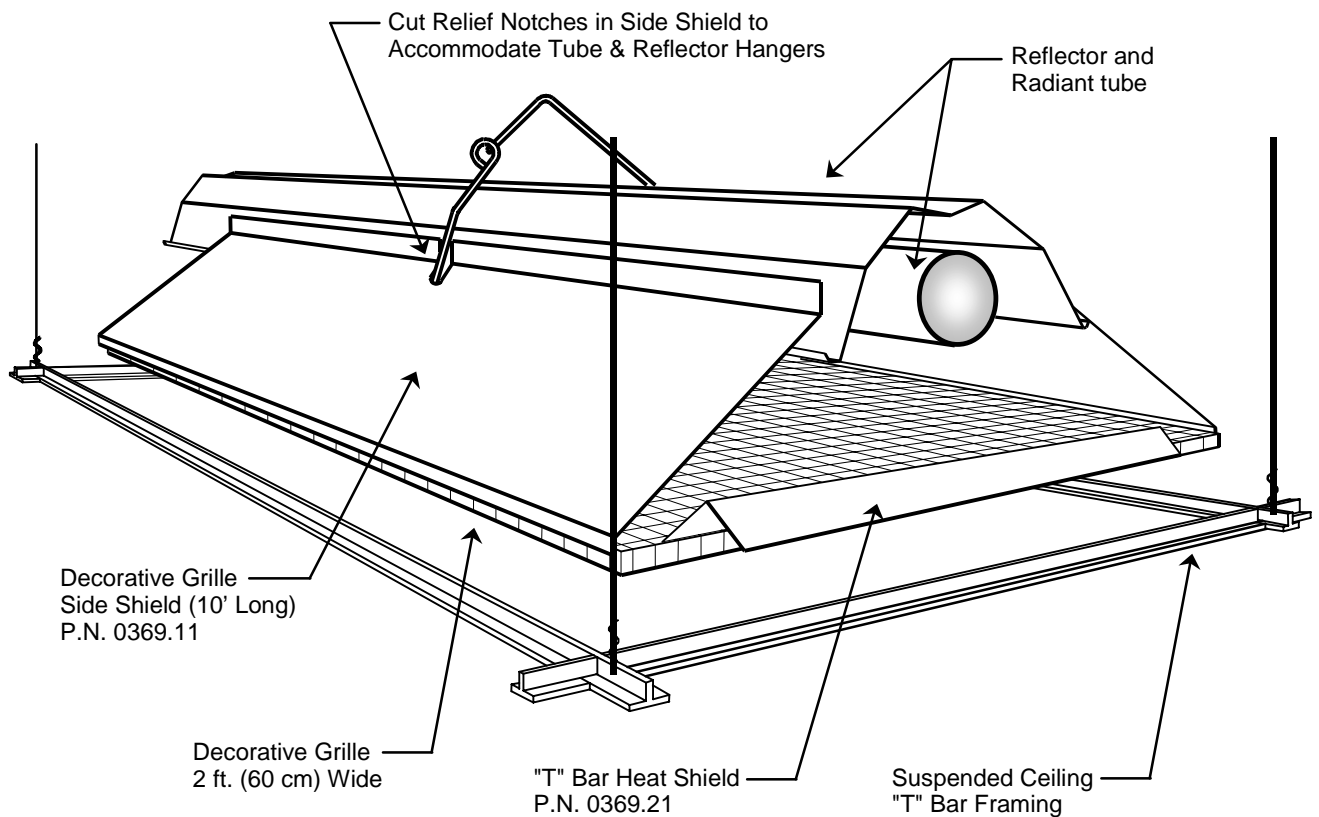

WALL PENETRATIONS

⚠ WARNING

FIRE HAZARD

IMPROPER INSTALLATION CAN CAUSE DEATH, SEVERE INJURY AND/OR PROPERTY DAMAGE.

Refer to the following instructions as well as the engineering drawing for proper installation of the Reflect-O-Ray® EDS 4 & EHS 4 System.

INSTALLATION:

Installation must comply with local building codes, or in the absence of local code, with the National Fuel Gas Code, ANSI Z223.1- (current standard) - same as NFPA Bulletin No. 54 for the United States and the CAN/CGA B149 (current standard) for Canada.

1. The wall penetration must be a minimum of:
 - a. 20' downstream of the burner for inputs of 40,000 to 75,000 Btu/hr.
 - b. 25' downstream of the burner for inputs of 80,000 to 125,000 Btu/hr.
 - c. 35' downstream of the burner for inputs of 130,000 to 175,000 Btu/hr.
 - d. 45' downstream of the burner for inputs of 180,000 to 250,000 Btu/hr.
2. A wall thimble suitable for 6", Type "B" vent (or better) must be used.
3. Use an all-steel 6" type "B" vent duct (or better). The 6" vent assembly must extend a minimum of 18" on either side of the wall. Secure the 6" type "B" vent to the wall thimble with sheet metal screws.
4. The Reflect-O-Ray® radiant tube should be positioned so that it passes through the middle or center of the 6" type "B" vent duct.
5. The reflectors, which are fitted with end caps, shall be within one inch of the end of the 6" type "B" vent duct.

NOTE: The illustration below depicts a penetration through a non-combustible wall. For penetrations through combustible walls contact the factory for guidance.

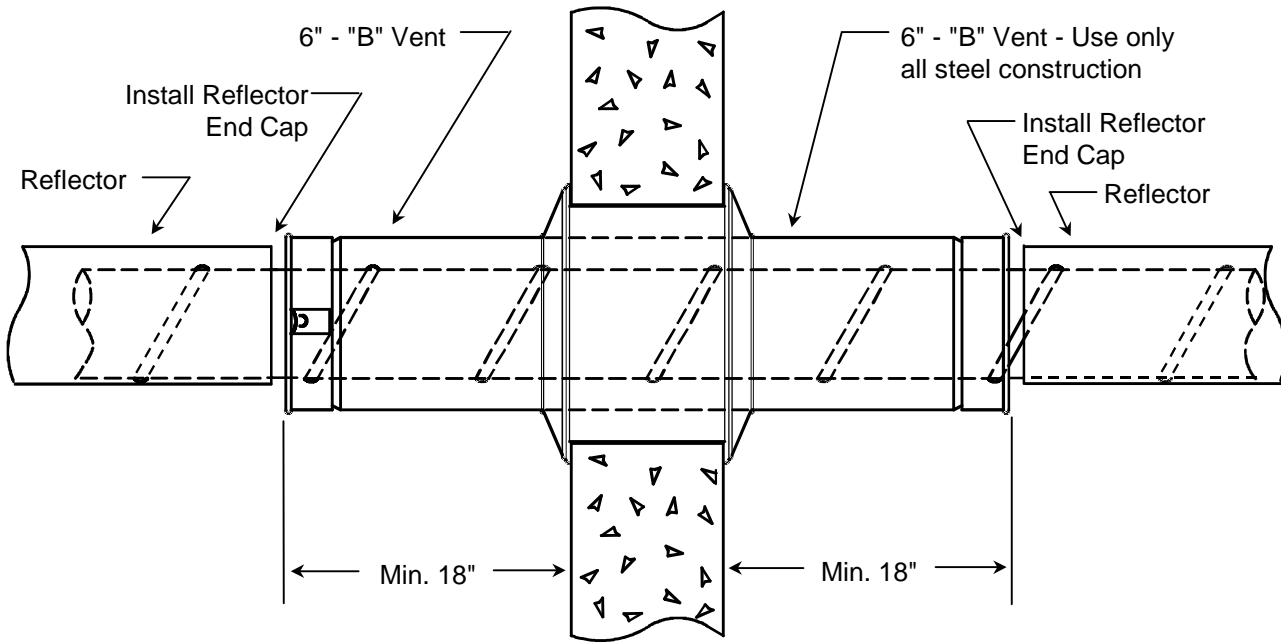

CONNECTING BURNER ASSEMBLY TO RADIANT TUBE/REFLECTOR ASSEMBLY

! WARNING

FIRE OR EXPLOSION HAZARD



IMPROPER INSTALLATION, ADJUSTMENT, ALTERATION, SERVICE OR MAINTENANCE CAN CAUSE DEATH, SEVERE INJURY AND/OR PROPERTY DAMAGE.

There is expansion of the radiant pipe with each firing cycle and this will cause the burner to move with respect to the gas line. This can cause an unsafe condition if the gas pipe connection is not done in strict accordance to the instructions.

1. Verify correct burner assembly for gas service, i.e., natural gas burner for natural gas supply.
2. Hang the burner so that it butts up to the 16 Ga. tube of the tubing and reflector assembly, and connect the two with the draw band coupler provided. **DO NOT APPLY SEALER TO THIS CONNECTION.** Position bolting assembly on the top of the tube assembly as shown. After tightening the coupler, check to make sure the burner is lined up squarely. Reposition as may be required, and re-tighten the draw band clamp.
3. The coupler flange should be positioned on the **TOPSIDE** of the tube. Tighten bolts on coupler to 50 to 70 ft. lbs. Secure with 2 sheet metal screws. See illustration below.

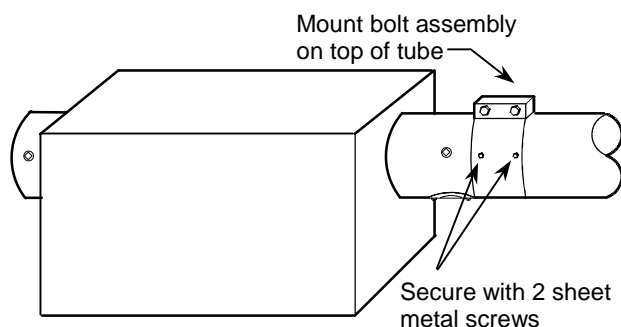

4. Connect the gas connector as outlined on page 19.
5. If used, connect the combustion air inlet as shown on page 20.

NOTES: Heater must be independently supported and not rely on the gas or electrical line for any of its support. If there is not a convenient point for suspending the hanging chain above the heater **DO NOT** try to "stretch" the span by having severe angles on the chain. Rather build a bridge between the existing building structure using angle

Iron, Uni-strut, etc. and then suspend the chain so that it hangs vertically.

GAS SUPPLY PIPING

Meter and service must be large enough to handle all the burners being installed plus any other connected load. When gas piping is not included in the layout drawing, the local gas supplier will usually help in planning the gas piping.

To check system supply pressure, a plugged 1/8" (3.2mm) pipe tapping is incorporated in the gas manifold of the burner, this will be the most remote location from the meter or gas supply. Joint compound resistant to the action of LP gases/propane gas should be used on all pipe threads.

CAUTION: FOR HIGH PRESSURE TESTING ON GAS PIPING, DISCONNECT COMPLETELY ALL BURNER UNITS AND THE SHUTOFF COCKS SUPPLIED WITH SAME: THEN INSTALL PIPE CAP ON SYSTEM AND CONDUCT TEST. FAILURE TO FOLLOW THIS PROCEDURE WILL EXCEED PRESSURE RATING OF BOTH BURNER GAS CONTROLS AND THE STOP COCK AND THIS WILL REQUIRE COMPLETE REPLACEMENT OF THESE PARTS AN OPTIONAL HIGH PRESSURE GAS VALVE MUST BE INSTALLED BY THE INSTALLING CONTRACTOR.

NOTE: A drip leg must be provided in the gas supply line. Check for gas leaks using a water and soap solution. Gas supply lines must be clear of dirt and debris. Purge supply lines of air before attempting to light burners.

GAS CONNECTORS

The purpose of the gas connector from the burner to the gas piping is twofold as follows:

1. To facilitate installation and replacement of the burner,
2. To accommodate movement between the burner and the gas piping. See Warning on this page.

Two methods are available for making this gas connection and the selection must be made by the designer to meet applicable local codes. Subject to this constraint of meeting local codes, these two methods are recommended as follows:

STANDARD INSTALLATION

Flexible gas connector assembly - As shown on the following pages.

NON STANDARD INSTALLATION

Rigid gas pipe connection to burner assembly - **NOT RECOMMENDED**, as this does not allow for movement due to system expansion.

Combustion Research Corporation does not recommend rigid construction.

GAS SUPPLY

In industrial installations where the natural gas pressure at the meter is available at higher pressure than the standard 7" TO 14" W.C., it may be possible to cut down on gas piping costs (when local codes and the Fire Marshal approve) by running high pressure gas lines inside the building or on the outside of the building. In no case should the pressure exceed 10% of the service supply pressure. When using a high pressure gas distribution system each heating zone should be equipped with a pounds to inches service regulator with soft seat, positive 100% lock-up. Allowing high gas pressure on the downstream side of the regulator will damage the control valve in the gas train. The outlet pressure of the service regulators should be set at 7" W.C. for natural gas and 11" W.C. for LP gases/propane gases. If it is not practical to regulate in "zones", each burner may be equipped with its own regulator.

To meet the requirements of 100% positive lock-up and internal relief vent must be piped to the outside of the building. It is recommended that an intermediate service regulator, such as a Maxitrol 325 Series or approved equal be used.

The typical discharge pressure on the down stream side of the gas meter furnished by the gas company is usually 5 P.S.I.G. while the discharge pressure of the regulator on the propane tank is usually set at 15 P.S.I.G.

Proper sizing of low and high pressure piping distribution systems for natural gas should be made in accordance with the National Fuel Gas Code, ANSI Z223.1 (current standard) NFPA No. 54. Consult the supplier of the propane tank and vaporizing system for the sizing of the piping system for LP gas pipe work.

When leak testing the gas piping system, the Reflect-O-Ray® burners must be isolated from the gas piping system. High-pressure compressed air used in the leak test will damage the control valve in the burner gas train, which will result in unsafe operation of the burner(s). For proper and safe test procedures, observe the provisions of Part #4, of the National Fuel Gas Code, ANSI Z223.1 (current standard) - *Inspection, Testing and Purging* or refer to equivalent local for the United States. In Canadian see gas code CAN/CGA-B149.1& CAN/CGA-B149.2.

NOTE: It is important that the entire system, up to the burner gas connection, be checked for leaks, prior to start up.

**TABLE
MAXIMUM CAPACITY OF PIPE IN CUBIC FEET OF GAS PER HOUR
(Pressure Drop of 0.5 Inch Water Column and 0.6 Specific Gravity Natural Gas)**

PIPE SIZE OF STANDARD SCH. 40 PIPE	TOTAL EQUIVALENT LENGTH OF PIPE (FEET)											
	10	20	30	40	50	75	100	125	150	175	200	250
1/2	120	85	70	60	54	44	38	34	31	29	27	24
3/4	272	193	157	136	115	99	82	76	67	65	58	52
1	545	385	315	272	244	198	173	154	141	130	122	109
1-1/4	1,201	848	693	600	537	439	380	340	310	287	268	240
1-1/2	1,862	1,316	1,074	931	832	680	588	527	480	445	416	372
2	3,766	2,663	2,174	1,884	1,680	1,373	1,190	1,065	971	900	841	753
2-1/2	6,165	4,358	3,559	3,082	2,752	2,254	1,950	1,743	1,593	1,473	1,379	1,233
3	10,502	7,426	6,063	5,250	5,015	3,841	3,549	3,106	2,895	2,682	2,508	2,242
4	22,031	15,577	12,718	11,015	10,510	8,158	7,430	6,548	6,060	5,066	5,250	4,700

**TABLE
MAXIMUM CAPACITY OF PIPE IN CUBIC FEET OF GAS PER HOUR
(Available Pressure 5 P.S.I.G. 10 % Pressure Drop and 0.6 Specific Gravity Natural Gas)**

PIPE SIZE OF STANDARD SCH. 40 PIPE	TOTAL EQUIVALENT LENGTH OF PIPE (FEET)										
	50	100	150	200	250	300	400	500	1,000	1,500	2,000
1	1,863	1,320	1,074	931	832	760	658	584	416	341	293
1-1/4	3,880	2,744	2,240	1,938	1,732	1,580	1,370	1,218	866	708	609
1-1/2	5,860	4,140	3,375	2,920	2,620	2,384	2,065	1,835	1,310	1,070	918
2	11,360	8,060	6,560	5,680	5,080	4,640	4,025	3,570	2,540	2,080	1,792
2-1/2	18,280	12,933	10,540	9,140	8,180	7,460	6,460	5,740	4,090	3,390	2,875
3	32,620	23,100	18,800	16,300	14,500	13,310	11,520	10,250	7,290	5,960	5,125
4	67,400	47,600	38,840	33,650	30,160	27,550	23,800	21,140	15,080	12,330	10,620
5	122,900	86,900	71,000	61,400	55,000	50,200	43,450	38,600	27,500	22,570	19,400
6	201,000	142,700	115,000	100,300	89,800	82,100	71,800	63,000	44,900	36,700	31,590
8	418,000	295,000	240,800	208,500	186,800	170,800	148,000	131,200	93,400	73,400	65,600

FLEXIBLE GAS CONNECTOR

⚠ WARNING

FIRE OR EXPLOSION HAZARD



IMPROPER INSTALLATION, ADJUSTMENT, ALTERATION, SERVICE OR MAINTENANCE CAN CAUSE DEATH, SEVERE INJURY AND/OR PROPERTY DAMAGE.

There is expansion of the radiant pipe with each firing cycle and this will cause the burner to move with respect to the gas line. This can cause an unsafe condition if the gas pipe connection is not done in strict accordance to the instructions.

United States - Use only the stainless steel flexible gas connector as supplied by Combustion Research Corporation.

Canada – Use approved gas connector as outlined in B149 Codes; Type 1, minimum 36” long. See chart below for sizing. This hose is to be supplied by the Installer contractor.

Install the flex connector as shown in the diagram below. This gas connector accommodates the normal expansion of the system. Before connecting the gas connector verify that all high-pressure testing has been completed.

- Do not high pressure test the gas piping with the burner connected. Failure to follow these instructions can result in property damage.
- Check the pipe and tubing ends for leaks before placing heating equipment into service. When checking for gas leaks, use a soap and water solution, never use an open flame. The loop of the gas flex **MUST BE** parallel or in line with the gas inlet pipe on the burner.
- The displacement as shown is for cold, non-firing condition. This displacement will vary as system heats up.
- Install drip leg in accordance with all applicable codes.
- **EXCESSIVE TORQUE ON THE BURNER GAS INLET MANIFOLD MAY CAUSE DAMAGE. ALWAYS USE TWO (2) WRENCHES WHEN MAKING PIPING CONNECTIONS TO THE BURNER.**
- **DO NOT APPLY PIPE DOPE TO FLARE NUT FITTINGS OF THE FLEXIBLE GAS CONNECTOR.**

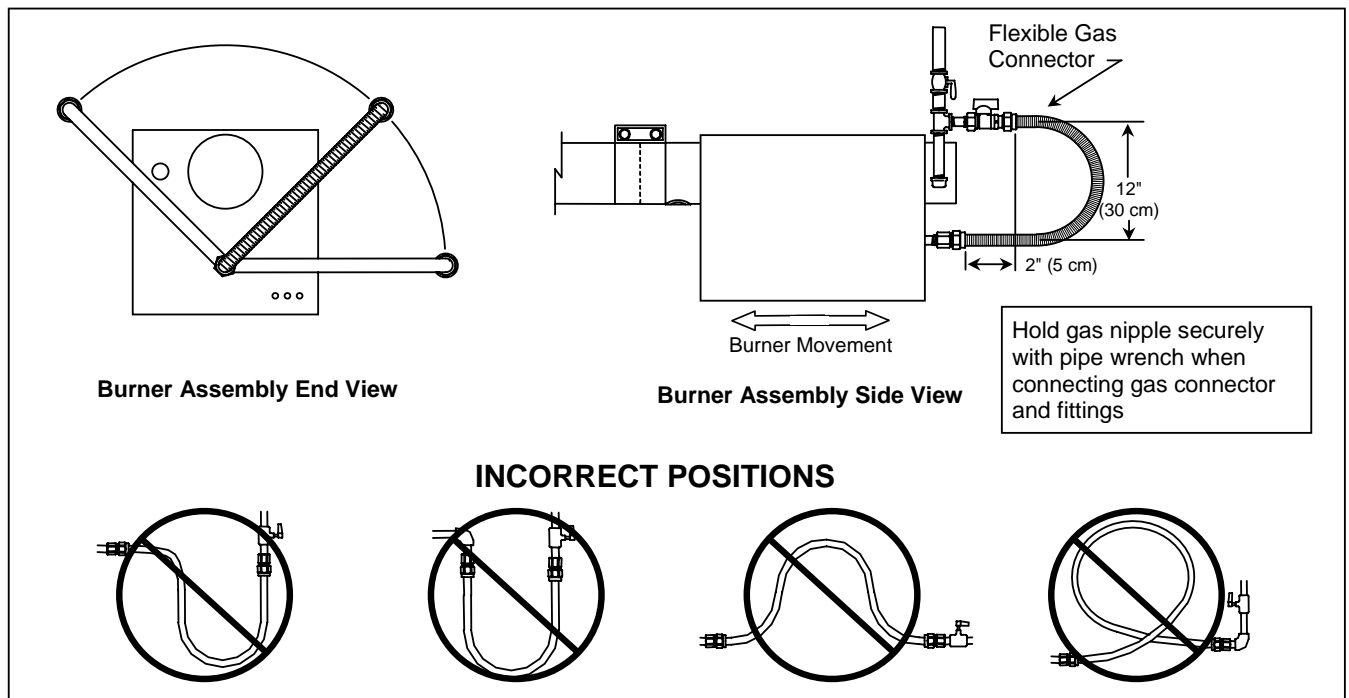

Gas Connector Description	Used With Inputs of	P/N
1/2" Flexible Stainless Steel Gas Connector (US Models) – 36" L	40K through 150K	0317.00
3/4" Flexible Stainless Steel Gas Connector (US Models) – 36" L	155K through 250K	0417.00
1/2" Flexible Type 1 Rubber Hose (Canada Only) – 36" L	40K through 175K	Supplied by Installer
3/4" Flexible Type 1 Rubber Hose (Canada Only) – 36" L	180K through 250K	Supplied by Installer

COMBUSTION AIR SUPPLY

NOTICE

Air that is not contaminated must be ducted to the heater if chlorinated or fluorinated contaminants, high humidity, other contaminants, or if negative pressure is present in the area where the heater is installed.

The *Reflect-O-Ray® EDS 4 & EHS 4* system is certified for installation with use of inside air as well as an outside air supply system. Some compounds such as halogenated hydrocarbons or other corrosive chemicals in the air can be drawn into the burner and cause an accelerated rate of corrosion of various parts of the system.

If the building has a slight negative pressure or air which contains contaminants it is strongly recommended that an outside air supply be used.

It is recommended that a minimum of 48" of straight 4.0" OD inlet be installed before each burner. Installation of elbows or "bends" any closer than 48" before each burner is not recommended. If space will not permit the minimum 48" of straight inlet, install a 4" tee as shown below.

1. The outside air intake consists of: 1 – 4" or 6" Inlet hood, 1 - 24" long 4.0" Dia. or 40" long 6.0" dia. flex duct, 2 - hose clamp.
2. It is recommended outside air intake assembly be used. This offsets problems of positive or negative building pressures, contaminated building air, etc. Combustion air may be drawn the space that is being heated.
3. The 4" duct assembly may extend in length of up to 100 feet by adding minimum 6" diameter sheet metal duct (P.D. 0.35" W.C. per 100 ft. of duct). A maximum of 3 elbows may be used.
4. System hanging chains must hang straight down and chain shall be closed loop type (CM Chain #3, or equal).
5. If wall is 10" or thicker, add length of appropriate diameter sheet metal duct.

DO NOT DRAW COMBUSTION AIR FROM ATTIC OR OTHER SIMILAR CONFINED SPACE.

DO NOT USE "DRYER" TYPE VINYL FLEX.

DO NOT EXCEED 24" OF FLEX.

Combustion Air Duct Size			
Burner No.	Input	Duct Size with 0101.040, 0102.040 or 0103.040 Vacuum Exhauster	Duct Size with 0201.040, 0401.040 or 0402.040 Vacuum Exhauster
08040 - 08175	(40k – 175k)	4" (101mm) Dia.	4" (101mm) Dia.
08180 - 08250	(180k – 250k)	6" (152mm) Dia.	4" (101mm) Dia.

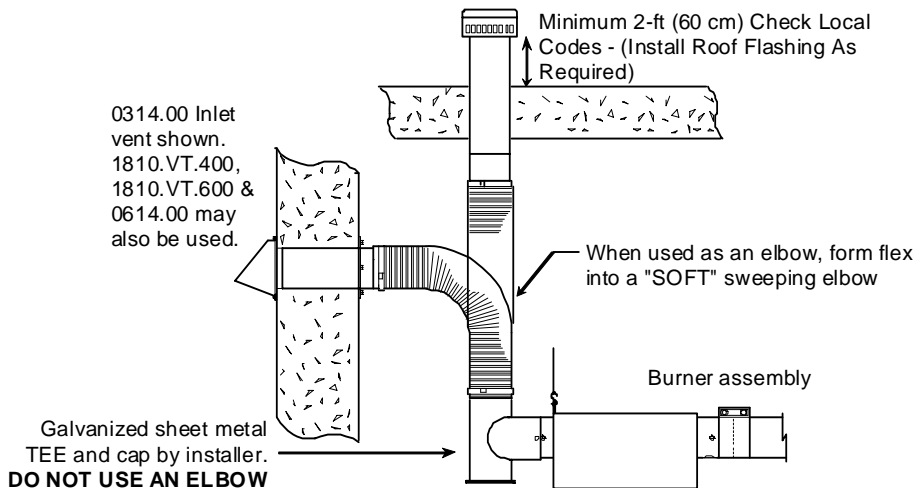
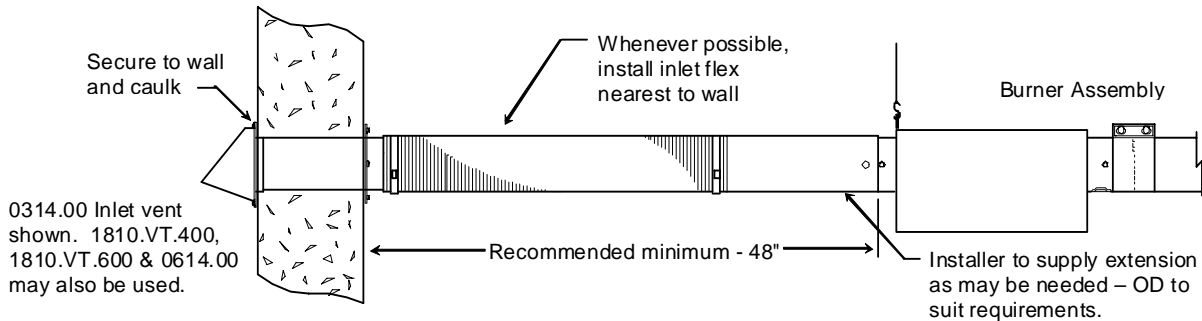

0401.040 & 0402.040 - VACUUM EXHAUSTERS

0401.040 - ½ HP, 115 / 208-230V, 6.2 / 3.1-3.0 FLA, 60 Hz, 1 Ph., 3450 RPM, totally enclosed motor (TENV or TEFC), thermally protected.

0402.040 - 1 HP, 115 / 208-230V, 12.4 / 3.0-2.7 FLA, 60 Hz, 1 Ph., 3450 RPM, totally enclosed motor (TENV or TEFC), thermally protected.

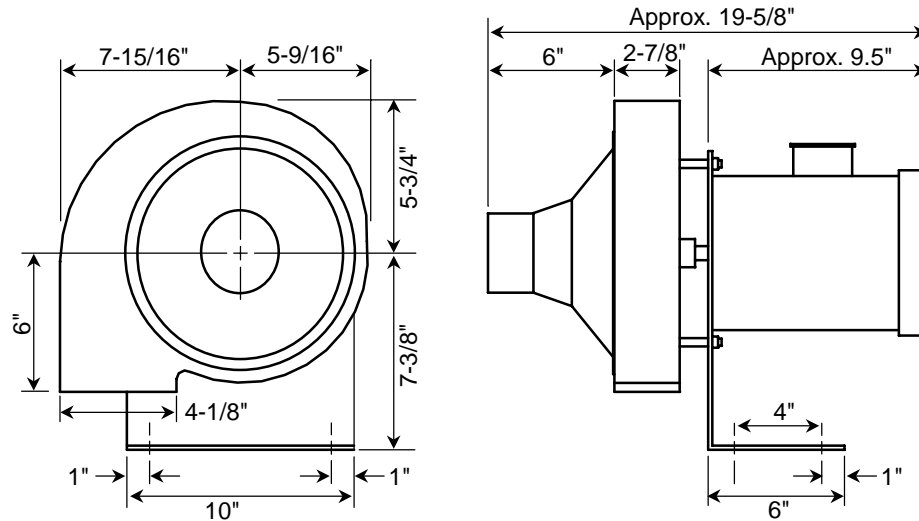

0201.040 VACUUM EXHAUSTER DATA

0201.040 - 1/4 HP, 115 / 208-230V, 3.6 / 3.0-3.0 FLA, 60 Hz, 1 Ph., 3450 RPM, totally enclosed motor (TENV or TEFC), thermally protected (NOTE – 1/3 HP motor may be substituted).

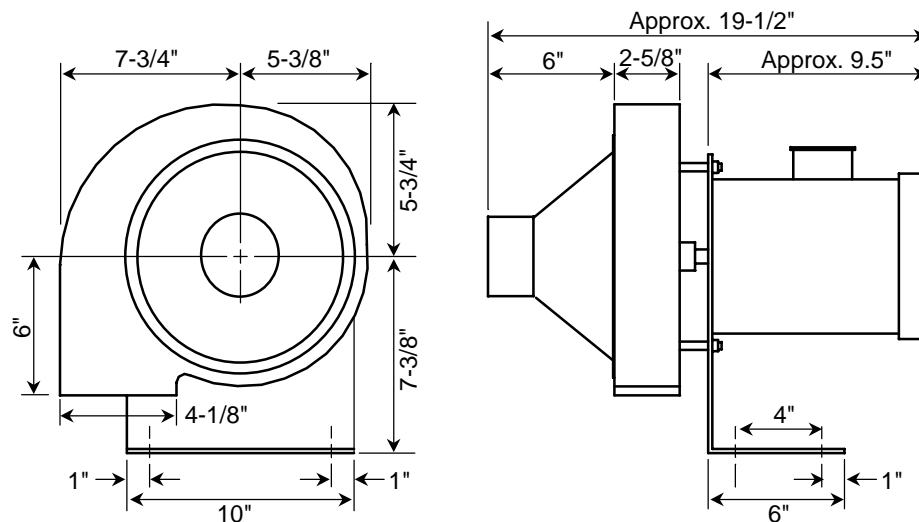

NOTE - Motor substitutions can occur, always refer to the motor manufacturer nameplate for electrical information and wiring instructions. Housings and inlets made with stainless steel are also available – the last two-digit designation will be SS.

0101.040 VACUUM EXHAUSTER DATA

0101.040 - 1/6 HP, 115V, 3.0 FLA, 60 Hz, 1 Ph., 3450 RPM, totally enclosed motor (TENV or TEFC), thermally protected.

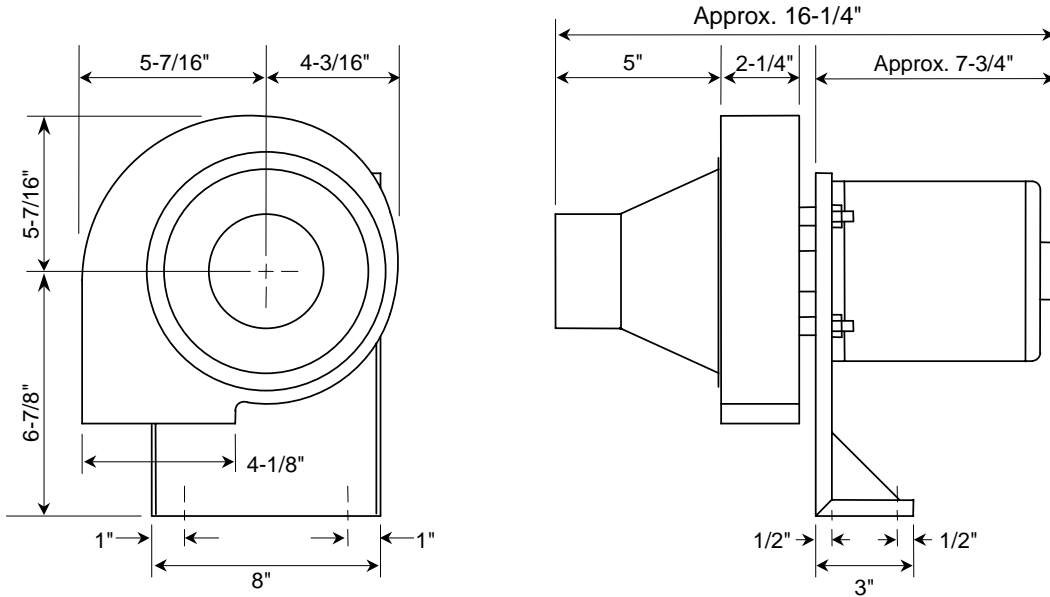

0102.040 VACUUM EXHAUSTER DATA

0102.040 - 115V, 3.0 FLA, 60 Hz, 1 Ph., 2300 RPM, motor thermally protected.

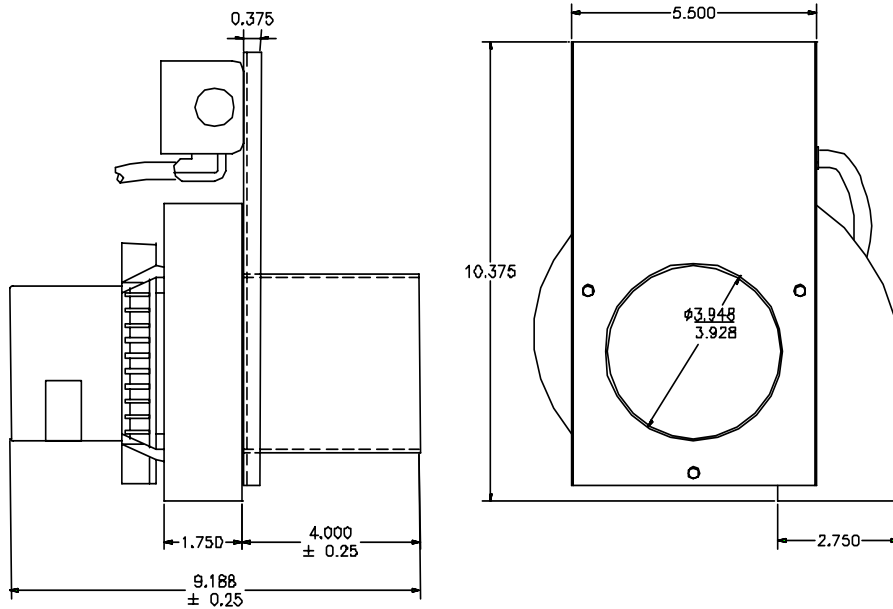

NOTE - Motor substitutions can occur, always refer to the motor manufacturer nameplate for electrical information and wiring instructions. Housings and inlets for 0101 vacuum exhauster made with stainless steel are also available – the last two-digit designation will be SS.

0103.040 VACUUM EXHAUSTER DATA

0103.040 - 115V, 3.0 FLA, 60 Hz, 1 Ph., 3000 RPM, motor thermally protected.

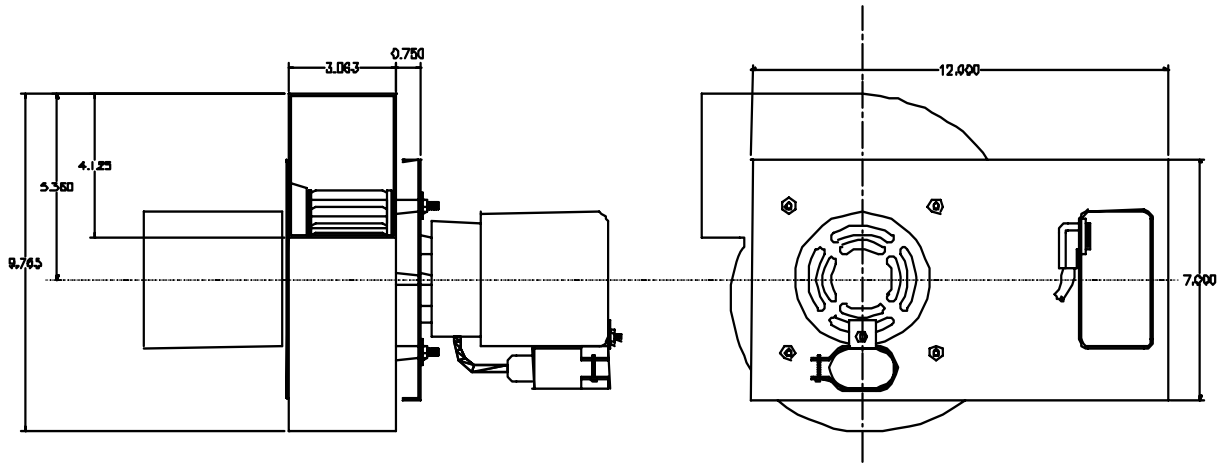

EXHAUST FLEX CONNECTIONS

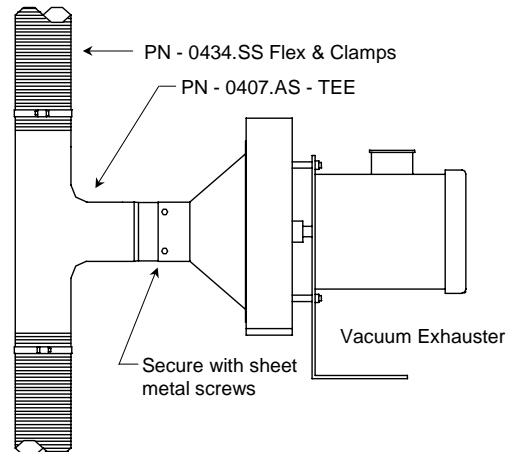
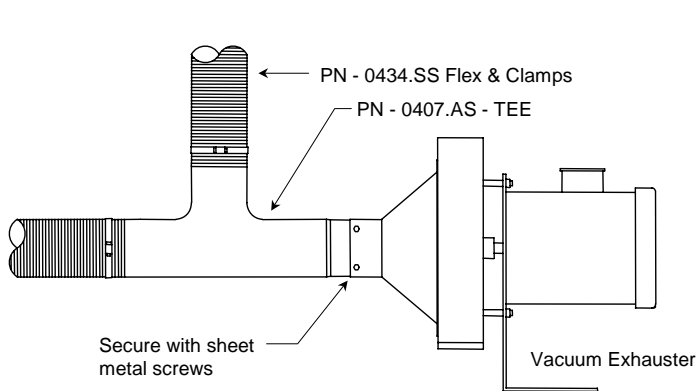
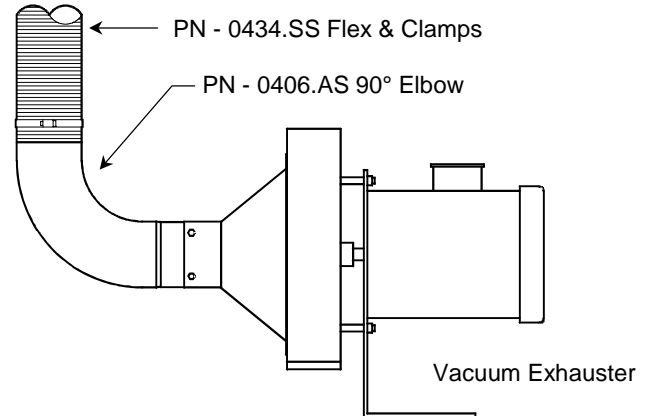
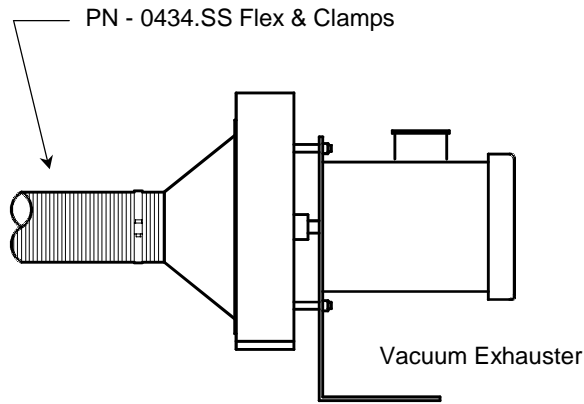

VENTING ARRANGEMENTS

WARNING



IMPROPER INSTALLATION CAN CAUSE DEATH, SEVERE INJURY AND/OR PROPERTY DAMAGE.

Improper venting and insufficient ventilation may result in health problems, carbon monoxide poisoning and death. Vent enclosed spaces and buildings according to national, state, provincial and local codes.

- ◆ This radiant heater must be vented in accordance with national, state, provincial and local codes and the guidelines in this manual. In the United States refer to the latest edition of the ANSI Z223.1 (NFPA 54) Standard and in Canada refer to the latest edition of the CAN/CGA B149.2 Standard.
- ◆ The layout drawing shows the general location of the vacuum exhauster. Specific exhauster location and discharge details must meet the following criteria:
- ◆ Make sure that the venting method selected is in compliance with local codes.
- ◆ Heater may be vented to the outdoors vertically or horizontally. The vent piping shall be adequately supported to prevent sagging.
- ◆ Horizontal discharge is preferred through side walls. The footage of horizontal vent pipe should be calculated into the maximum system footage as outlined in the charts on page 3 & 4. Vertical discharge must be arranged as shown on page 26.
- ◆ Where the vent pipe passes through areas where the ambient temperature is likely to induce condensation of the flue gases the vent pipe shall be insulated.
- ◆ If the heater is to be vented horizontally:
 - a. Vent must terminate at least 3 feet (0.9m) above any forced air inlet located within 10 feet (3.1m).
 - b. Vent shall terminate at least 4 feet (1.2m) below, 4 feet (1.2m) horizontally from, 1 foot (30cm) above any door, window, or gravity air inlet into any building.
 - c. The bottom of the vent terminal shall be located at least 12 inches (30cm) above grade and at least 6 inches (15cm) above anticipated snow depth.
 - d. Distances from adjacent public walkways, adjacent buildings openable windows and building openings, are to be consistent with ANSI Z223.1 (NFPA 54) Standard and the CAN/CGA B149.2 Standard.
 - e. Vent must not terminate less than 6-ft (1.8m) from a combustion air inlet of another appliance.
 - f. Vent must not terminate above a gas utility meter or service regulator.
 - g. Vent terminal shall not be less than 7-ft (2.1m) above grade.

- ◆ Vent opening must be beyond any combustible overhang.
- ◆ Any portion of the flue pipe that passes through combustible material of the building must have a minimum 1" clearance.
- ◆ If condensation within the flue becomes a problem, the flue should be shortened or insulated.
- ◆ Building materials should be protected from degradation by flue gas products.

Recommended practice is to mount the vacuum exhauster on the building inside wall. Alternatively the vacuum exhauster may be suspended from the ceiling.

The vacuum exhauster can be mounted outside either on roof or out side wall. The vacuum exhauster must be protected from weather by mounting a hood over the entire assembly. Vacuum exhausters are shipped completely assembled. Scroll can only be rotated in 90° increments.

The vacuum exhauster shall be installed so that the discharge is bottom horizontal. Any other arrangement will permit condensation to collect in scroll and cause premature failure of scroll. For minimum corrosion of scroll when mounted outside and the metal temperature of the scroll is less than 150°F, it is recommended that the casing be suitably insulated for protection against the weather.

Motor and exhauster impellers are precision balanced and bench tested as a complete assembly for vibration and noise. It is important that care be used when handling the vacuum exhauster to insure that it is not put out of balance by dropping or careless handling.

Install the vibration isolating stainless steel flex (PN 0434.SS) as may be shown in the layout drawing. The stainless steel exhaust flex is to be installed in a straight line, rather than formed into an elbow.

The PN 0119.00, 0219.00 & 0419.00 exhaust vents are provided with stainless steel bird screen as standard when furnished by Combustion Research Corporation.

OPERATION

1. Before connecting the motor to the electric supply, check the electrical characteristics as indicated on the motor nameplate to insure proper voltage, phase, and rotation.
2. After electrical connections are completed, momentarily apply power, just enough to start the vacuum exhauster unit. Be sure that the rotation of the wheel is correct as indicated by directional arrows on the unit. If proper rotation, apply full electrical power.
3. With the complete system in full operation and all ducts attached, measure current input to the motor and compare with the nameplate rating to determine if the motor is operating under safe load conditions.

VENTING ARRANGEMENTS

For Reflect-O-Ray® EDS 4 systems only

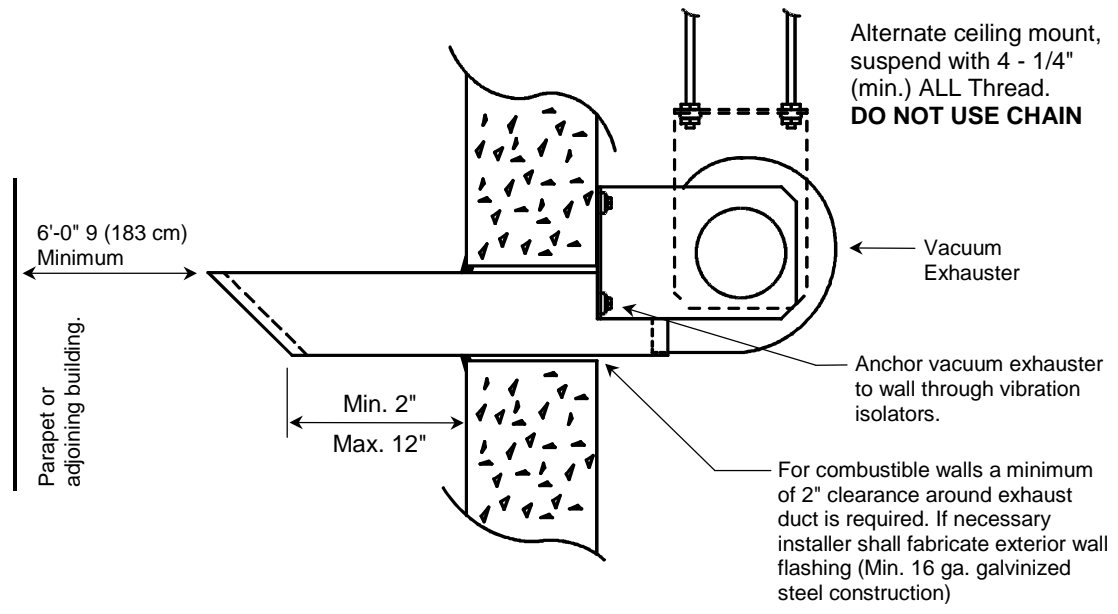
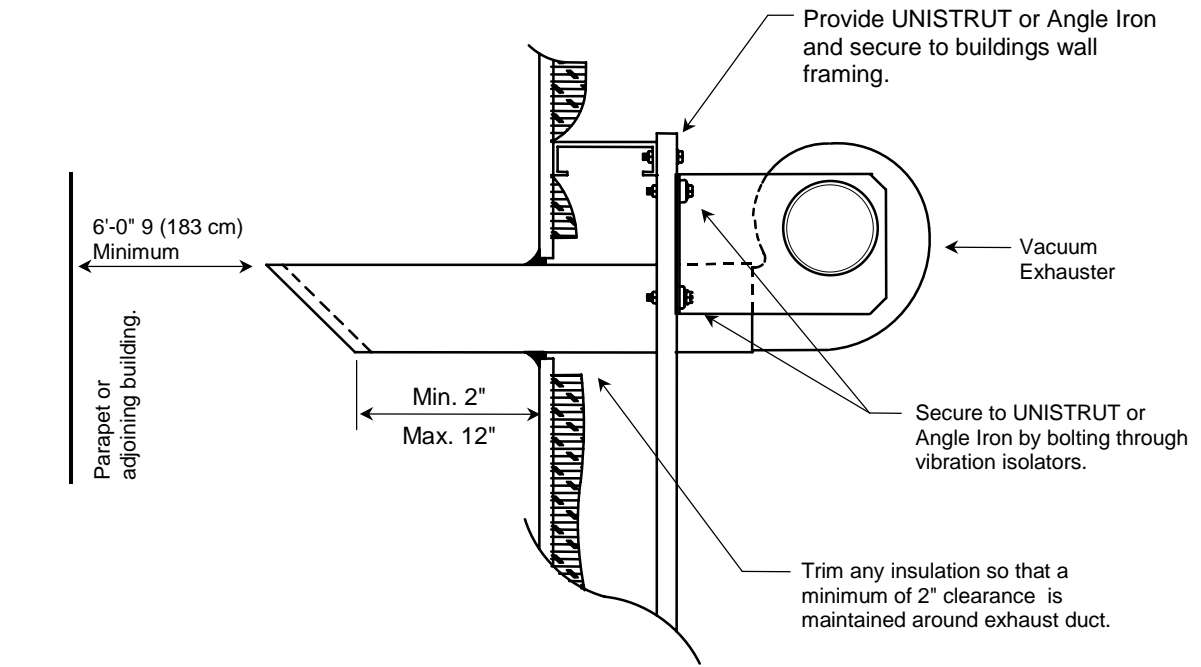

VENTING ARRANGEMENTS

For Reflect-O-Ray® EDS 4 and EHS 4 systems

Use a Maximum of 20' of vent pipe for the Reflect-O-Ray® systems.

1/4HP and Larger Vacuum Exhausters, Suspend with a Quantity of 4 - 1/4" (min.) ALL Thread – Length to Suit.
DO NOT USE CHAIN

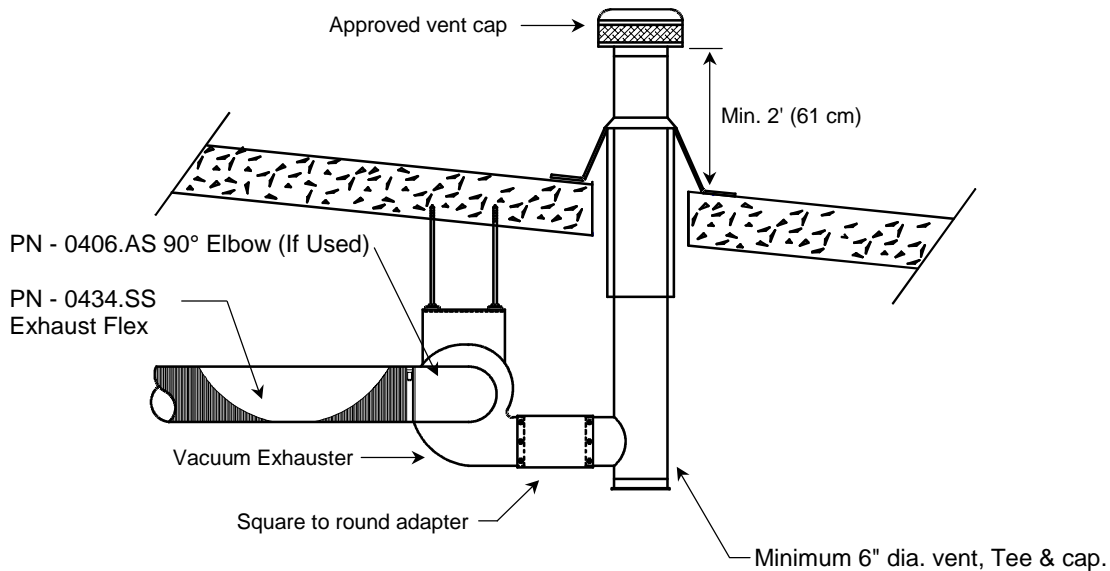
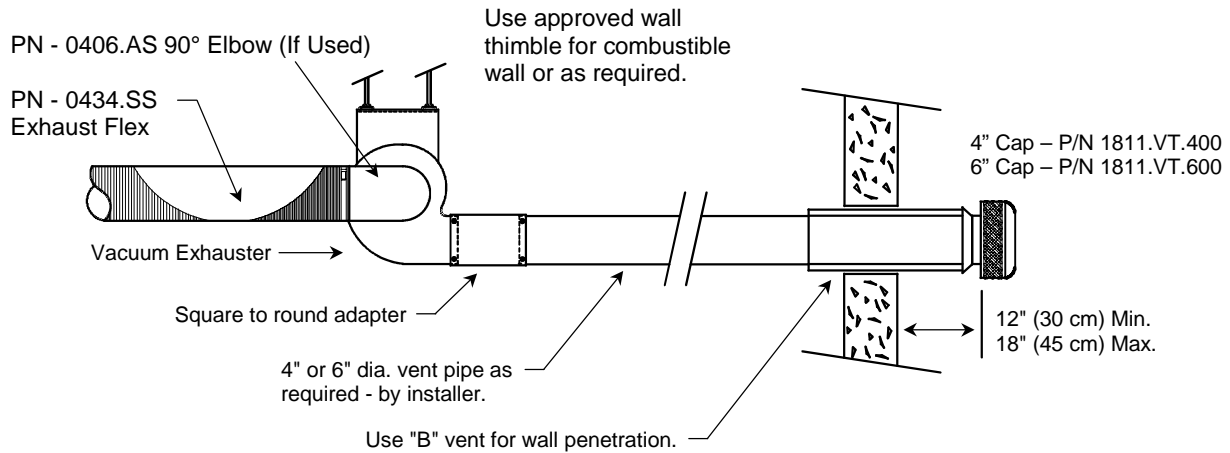

VACUUM EXHAUSTER EXTERIOR MOUNTING

The *Reflect-O-Ray® vacuum exhauster* can be mounted on the exterior of the building provided appropriate weather covers are installed. The vacuum exhauster is to be mounted bottom horizontal discharge. It is recommended that all exterior ducting be insulated or use double wall vent pipe. Weather covers are to be fabricated

from 16 gauge hot-dipped galvanized steel. Caulk all seams.

To accommodate expansion and vibration install the 0434.SS exhaust flex below the roofline.

Maintain a minimum of 3 feet (92cm) above exhaust outlet to roof or overhang and a minimum of 6 feet (184cm) to adjoining building or parapet. Exhaust outlet must be at least 6" (15cm) above anticipated snow depth.

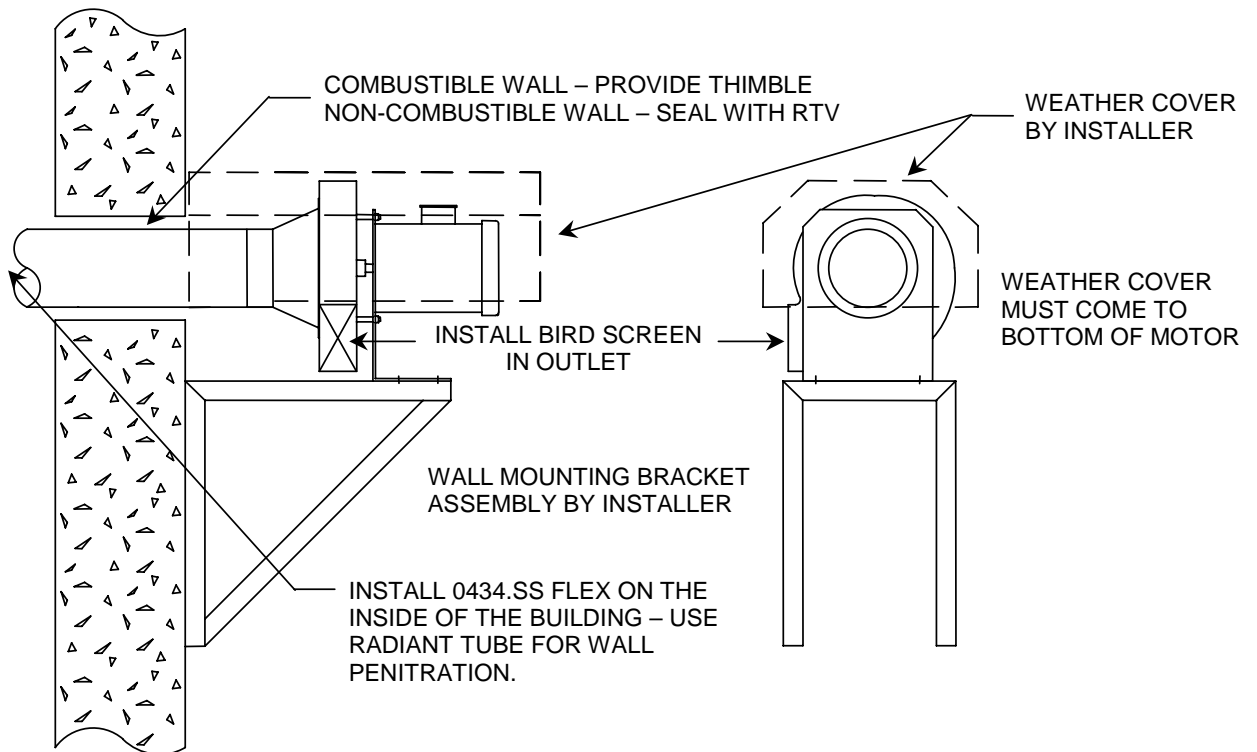
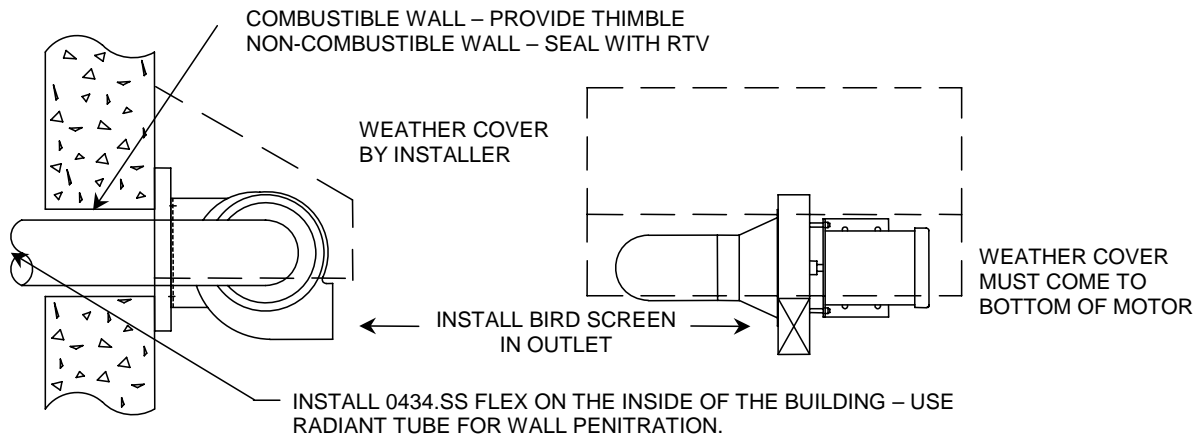

ELECTRICAL WIRING CRITERIA

WARNING

ELECTRICAL SHOCK



DANGER OF SEVERE INJURY
OR DEATH

Field wiring to the heater and vacuum exhauster must be connected and grounded in accordance with national, state, provincial, local codes and to the guidelines outlined in this manual. In the United States refer to the most current revisions to the National Electric Code and in Canada refer to the most current revisions to the Canadian Electrical Code Part I Standard.

DO NOT use unless electrical wiring complies with all applicable codes.

DO NOT wire without providing for a power source disconnect at the burner assembly and the Vacuum Exhauster.

The requirements and practices described below are based on the National Electrical Code ANSI/NFPA No. 70- (current standard) and the Space Heating Standard or the Underwriters Laboratories, Inc. (UL), the Canadian Electrical Code CSA C22.1 Part 1 (current standard) apply in Canada. Although UL & CSA requirements are uniform throughout the country, local electrical codes may deviate from these codes, therefore local inspection authorities should be consulted regarding local requirements.

After final assembly and before shipping, each *Reflect-O-Ray® EDS 4 & EHS 4* burner must pass a 500 volt minimum dielectric test.

VACUUM EXHAUSTERS

Safety control circuits must be a two-wire, with ground, and have a nominal voltage not exceeding 125 volts. A safety control or protection device must be connected so as to interrupt the ungrounded conductor.

BURNERS

Safety control circuits must be two wire and have a nominal voltage not exceeding 24 volts. The control circuit shall be connected to a power supply branch circuit fused at not more than the value appropriate for the rating of any control or device included in the circuit.

Large enough wire must be used in connecting a *Reflect-O-Ray® EDS 4 & EHS 4* system. This is necessary for two reasons - carrying capacity, and voltage drop. The wire size necessary to provide carrying capacity without overheating is generally determined by the electrical code which specify a minimum wire size for the amperage used. These requirements are intended to prevent overheating and take no account of the length of wire. Most problems have been caused by voltage drop due to long runs, or low voltage furnished by the utility.

In order to assure proper operation of the electrical components of the *Reflect-O-Ray® EDS 4 & EHS 4* system, it is essential that the voltage to the exhauster motor and burner controls is sufficient. It must be within 10 percent of the nameplate rating under all conditions to assure satisfactory operation. It is preferable that it be within 5 percent. Almost all complaints of motor not starting or not reaching operating speed are caused by low voltage reaching the motor. This voltage is dependent upon three things:

1. The voltage furnished by the Power Company.
2. The size (gauge) of the electrical wiring to the motor.
3. The length of the wiring.

Warning Do not use 277 volt.

When supplying single phase from a three-phase system, use a suitable sized machine tool transformer to transform the 460V or 230V three-phase to 230V or 115V single phase. Under no circumstances use 277V single phase input to the *Reflect-O-Ray® EDS 4 & EHS 4* system. The resulting output from a two-to-one transformer would be 138V single phase. These high voltages exceed the allowable 10% voltage variation from the normal and will damage the electrical components, such as the 24V transformer, control valve and exhauster motors of the *Reflect-O-Ray® EDS 4 & EHS 4* system.

BURNER GROUNDING

It is necessary for the circuit ground, (L2) and chassis ground to be common and maintained to an earthen ground rod using copper (not aluminum) ground wires throughout. Do not assume ground continuity to an earth ground via gas piping, burner tubes, electrical conduits or building structural steel. These should not be assumed as proper positive earth grounds.

Burner Wiring - Use minimum 18 Ga., 2 Conductor Control Cable for wiring between control transformer and burner. The low voltage wiring on the secondary or the transformer includes two wires for each burner. A third grounding wire may be necessary for connection of burner chassis to a good earth ground. Do not use control circuit completion connections in this ground circuit.

The correct size wire should be carefully selected before the installation is made. The first step is to establish what voltage will be coming into the building. This will vary throughout the country and must be determined locally by checking with your power company and using experience gained with other installations in your geographic area. Once the minimum voltage available is established, you will know how much voltage drop can be permitted in the wiring. The following chart shows maximum wire lengths (one way, not the length back and forth) to keep voltage drop to a minimum of 10 percent at various currents at 115V.

The lengths shown in the following chart should never be exceeded and in many cases it will be necessary to reduce them to accommodate low voltage supplied to the building. If 5 percent voltage drop is desired, the lengths will be one-half of those shown. Permissible lengths for other voltage drops will be in the same proportion, i.e., 8 percent = 80 percent of length shown, etc.

WIRE LENGTH FOR 10% VOLTAGE DROP IN FEET - 115V 60HZ				
AMPERES	COPPER WIRE SIZE			
	No. 14	No. 12	No. 10	No. 8
15	150	225	350	600
20	110	175	275	450
25	90	140	225	350
30	75	125	150	300
35	-	100	135	250
40	-	85	125	225
45	-	-	110	200
50	-	-	-	175

The performance of an electric motor drops rapidly as the voltage at its terminal is reduced. A 10 percent drop in voltage reduces its output by about 20 percent. In order to ensure proper operation, the motor must receive as close to nameplate voltage as possible during start-up when the amp draw is at it's highest.

AMPERE REQUIREMENTS OF Reflect-O-Ray® COMPONENTS

- ◆ All burner assemblies - 32VA - 24V or 115V - 1.3 amp
- ◆ 0402.040 - 1 HP Vacuum Exhauster FLA - 12.4/6.7 amps 115V/230V
- ◆ 0401.040 - 1/2 HP Vacuum Exhauster FLA - 5.4/3.0 amps 115V/230V
- ◆ 0201.040 - 1/4 HP Vacuum Exhauster FLA - 3.6/1.8 amps 115V/230V
- ◆ 0101.040 - 1/6 HP Vacuum Exhauster FLA - 3.0 amps 115V
- ◆ 0102.040 - 2300 RPM Vacuum Exhauster FLA - 1.15 amps 115V
- ◆ 0103.040 - 1/8 HP Vacuum Exhauster FLA - 1.8 amps, 115V
- ◆ 5487.00 - Thermostat Contact rating 16 amps - 24 VAC to 115 V.A.C.
- ◆ 5484.00 - Thermostat Contact rating 9.8 amps - 24 VAC to 115 V.A.C.

BASIC SYSTEM HOOK-UP

⚠ WARNING

FIRE OR EXPLOSION HAZARD



IMPROPER INSTALLATION, ADJUSTMENT, ALTERATION, SERVICE OR MAINTENANCE CAN CAUSE DEATH, SEVERE INJURY AND/OR PROPERTY DAMAGE.

The thermostat must control both the Vacuum exhauster and Burner(s). **DO NOT CONTROL SEPARATELY.** Burner(s) **MUST NOT** be wired "HOT". Refer to the electrical wiring section of this manual.

Referring to the following diagram, we see a basic configuration that uses a line voltage thermostat to control power supply to the vacuum exhauster and burner transformers. Typically the burner transformers are mounted near the vacuum exhauster.

The **THERMOSTAT DIRECTLY POWERS BOTH THE VACUUM EXHAUSTER AND THE BURNER TRANSFORMER(S)**. The transformer(s) steps the line voltage (115 VOLTS) down to 24 VOLTS.

Consult the factory for alternate voltage requirements.

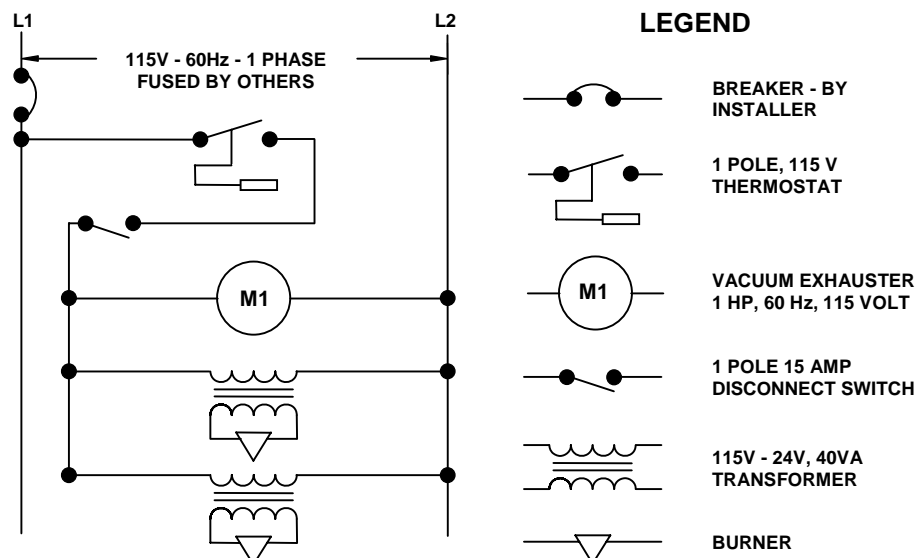

INTRODUCTION

The basic *Reflect-O-Ray*® EDS 4 & EHS 4 system has a built-in pre-purge of approximately 10 air changes. The system also has up to two air changes of post purge as the vacuum exhauster "coasts" to a stop.

Where a longer pre purge and post purge is specified, a pre-wired series 5500 control panel is available.

The series 5500 control systems includes these basic functions:

1. Additional protection for the system.
2. Approximately 40 seconds of pre purge.
3. Approximately 40 seconds of post purge.

The pre purge and post purge cycles will provide in excess of 12 additional air changes within the radiant tubing network.

The line voltage thermostat will prevent the system from "short cycling" and allow the system to run long enough to dry out the startup condensation within the radiant tubing. The system must not be allowed to short cycle as required and outlined in the warranty statement. It is recommended that a line voltage thermostat be used when a 24V-thermostat control is required.

Please note that the timings listed may vary slightly from system to system.

NOTE: *Reflect-O-Ray*® EDS 4 & EHS 4 burners require the use of one 24 VAC, 40VA transformer per burner assembly. It is recommended that the transformer(s) supplied with each burner be mounted as a cluster on the 5500 control panel or remotely when voltage drop on long runs may be a problem.

5500.00 CONTROL PANEL PRE & POST PURGE W/115V T/STAT

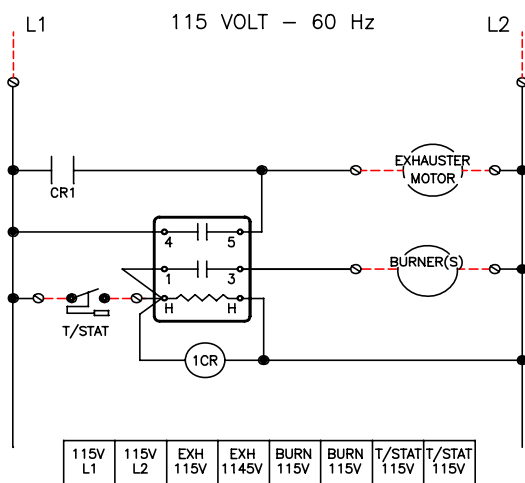

5500.03 CONTROL PANEL MINIMUM RUN TIME WITH PRE & POST PURGE & 115V T/STAT

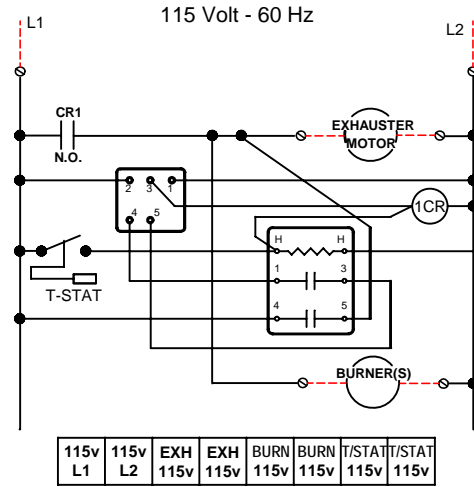

5500.04 CONTROL PANEL PRE & POST PURGE W/24V T/STAT

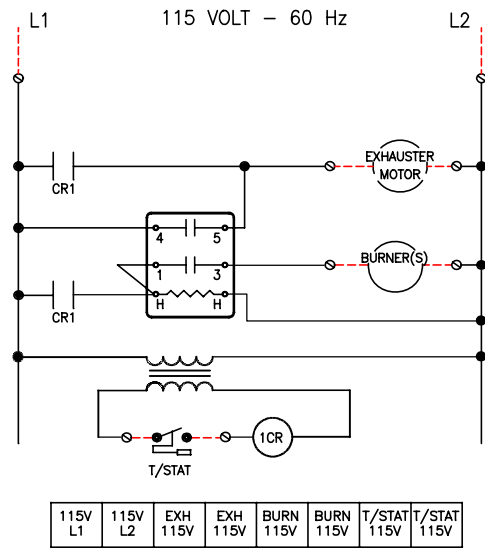

Custom control panels can be made. Consult your representative or Combustion Research Corporation with your requirements.

BURNER INTERNAL WIRING

**Internal Wiring Diagram for Reflect-O-Ray® EDS 4 & EHS 4 Systems
Fenwall Ignition Control**

Point To Point Diagram

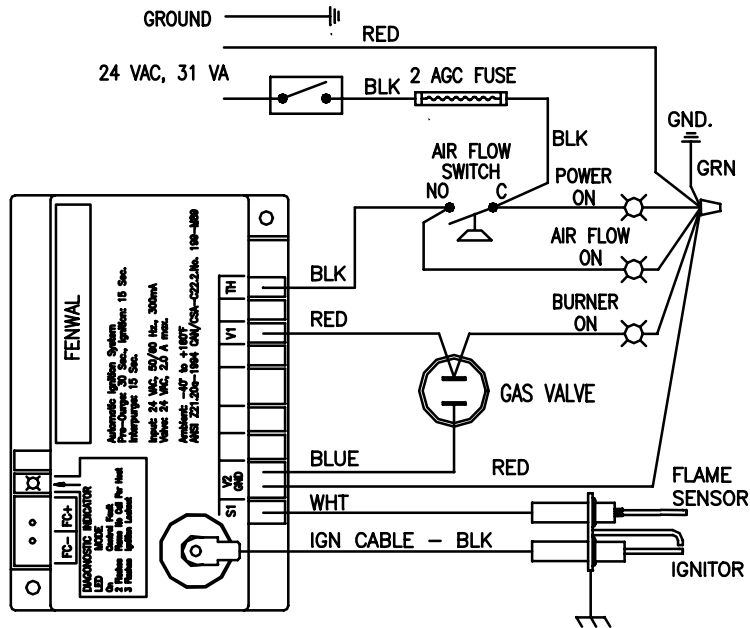

Ladder Diagram

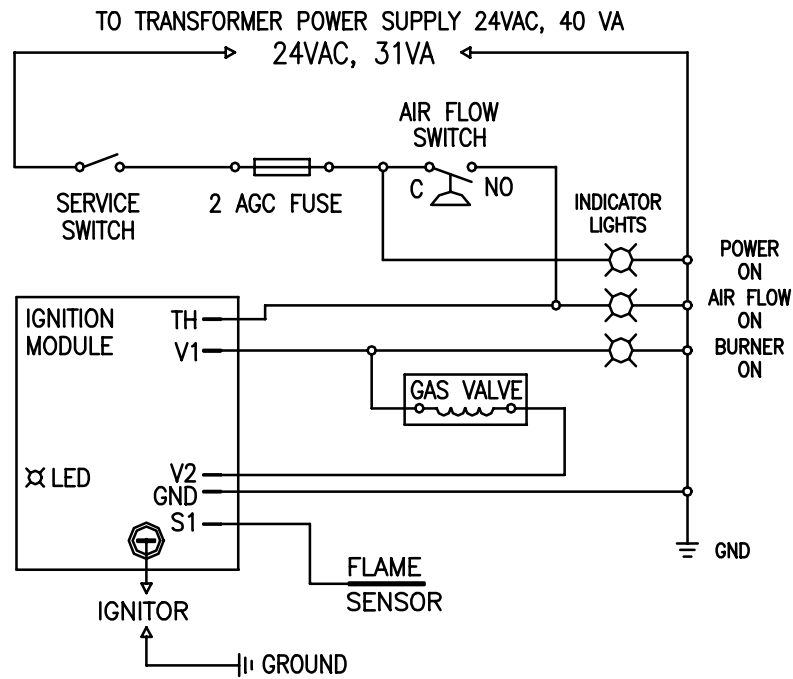

GAS PRESSURE AT MANIFOLD

Natural Gas: 3.5" W.C.
 LP Gas: 10.0" W.C.
 1/2" NPT Gas Connector Size

BURNER ASSEMBLY ELECTRICAL RATING

24 VAC, 50/60 Hz., 31 VA (STANDARD)
 (Optional - 115 VAC hook up-available)

GAS INLET PRESSURE

Natural Gas: 5.0" Minimum 14.0" Maximum
 LP Gas: 11.0" Minimum 14.0" Maximum

ALTITUDE

United States: 0 – 2,000 Ft. (0 - 609 m)
 Canada: 0 – 2,000 Ft. (0 - 609 m) Inputs of 180K – 250k
 0 - 4,500 Ft. (0 - 1,370 m) Inputs of 40k to 175K

MANIFOLD PRESSURE SETTINGS

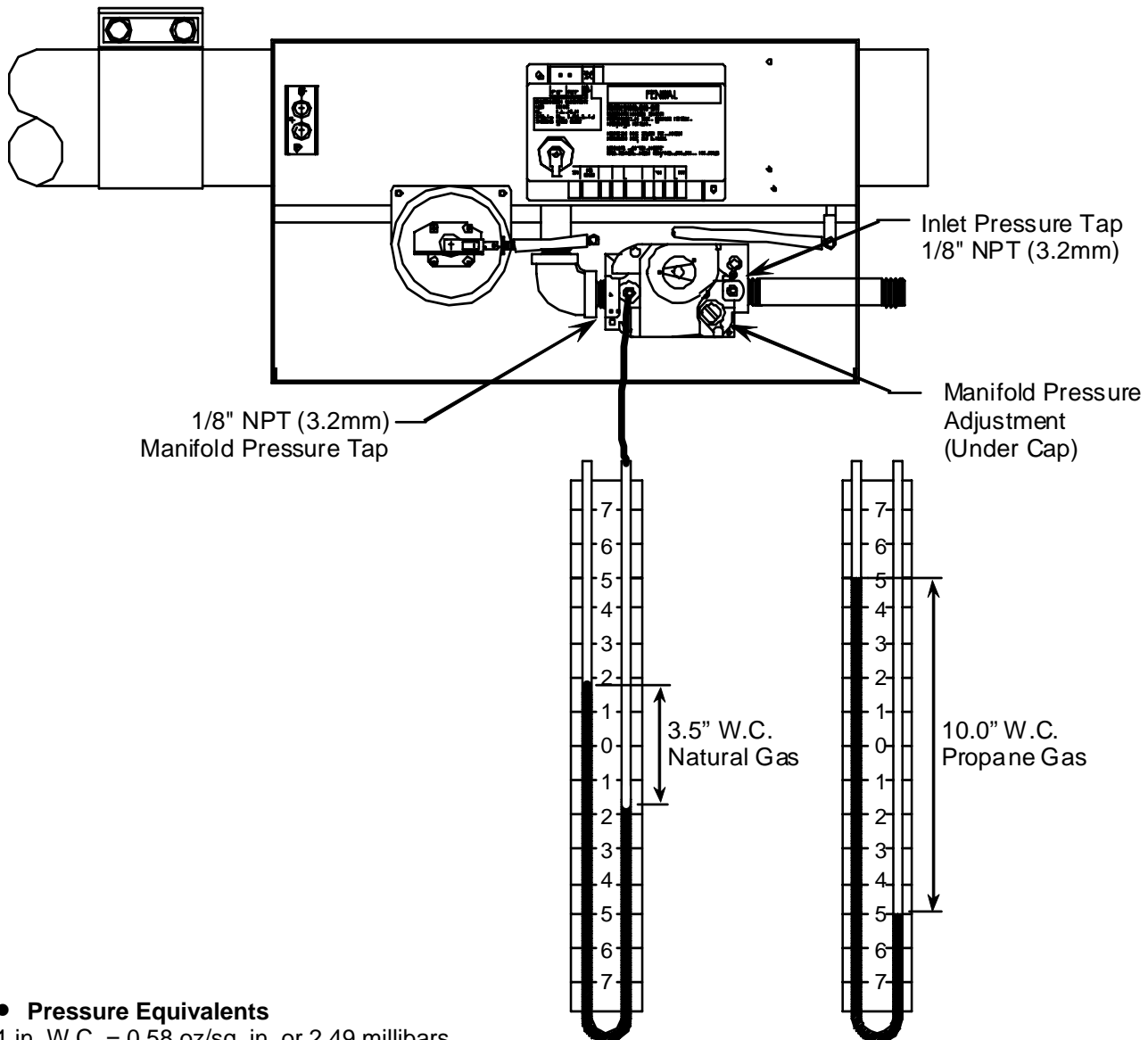

- **Pressure Equivalents**
 1 in. W.C. = 0.58 oz./sq. in. or 2.49 millibars

BURNER SETUP

Each *Reflect-O-Ray*® EDS 4 & EHS 4 burner assembly is marked with the input firing rate and fuel designation on the nameplate. Refer to the following chart for correct manifold pressure and vacuum readings.

When the system is equipped with fresh air inlet ducting, the vacuum reading must be read as a differential across the entire burner. Use the test ports located inside the burner. See diagram below

NOTE: Gas pressures must be measured with a water or red oil manometer – DO USE NOT A DIAL GAUGE. All measurements must be made when this heater and all other gas burning equipment connected to the gas supply system are operating at maximum capacity. It should be assured by test that the gas pressure at the burner inlet is not greater than the figures given above. Maximum inlet pressure is 1/2 lb. or 14.0" W.C (3.48 Kpa).

The installer must provide a 1/8" NPT (3.2mm) plugged tapping, accessible for test gauge connection, immediately upstream of the gas supply.

1. Set thermostat above room temperature.
2. Allow the system to operate for at least twenty (20) minutes for temperature to normalize before setting the vacuum. Connect manometer to the pressure ports shown below. NOTE: The caps must be replaced after the vacuum has been set.
3. The cold vacuum reading will be approximately 0.75" to 1.0" W.C. (0.18 to 0.25 Kpa), this will vary depending on the burner input and radiant tube length. The operating vacuum pressure is to be set for 0.6" to 0.7" W.C (0.15 to 0.17 Kpa). The vacuum can be adjusted by opening or closing the damper downstream of the burner.
4. Lock dampers in place by installing a self-drilling and taping screw in the handle assembly of the damper.
5. Re-install burner cover and set the thermostat to desired room temperature.

VACUUM TEST CONNECTIONS

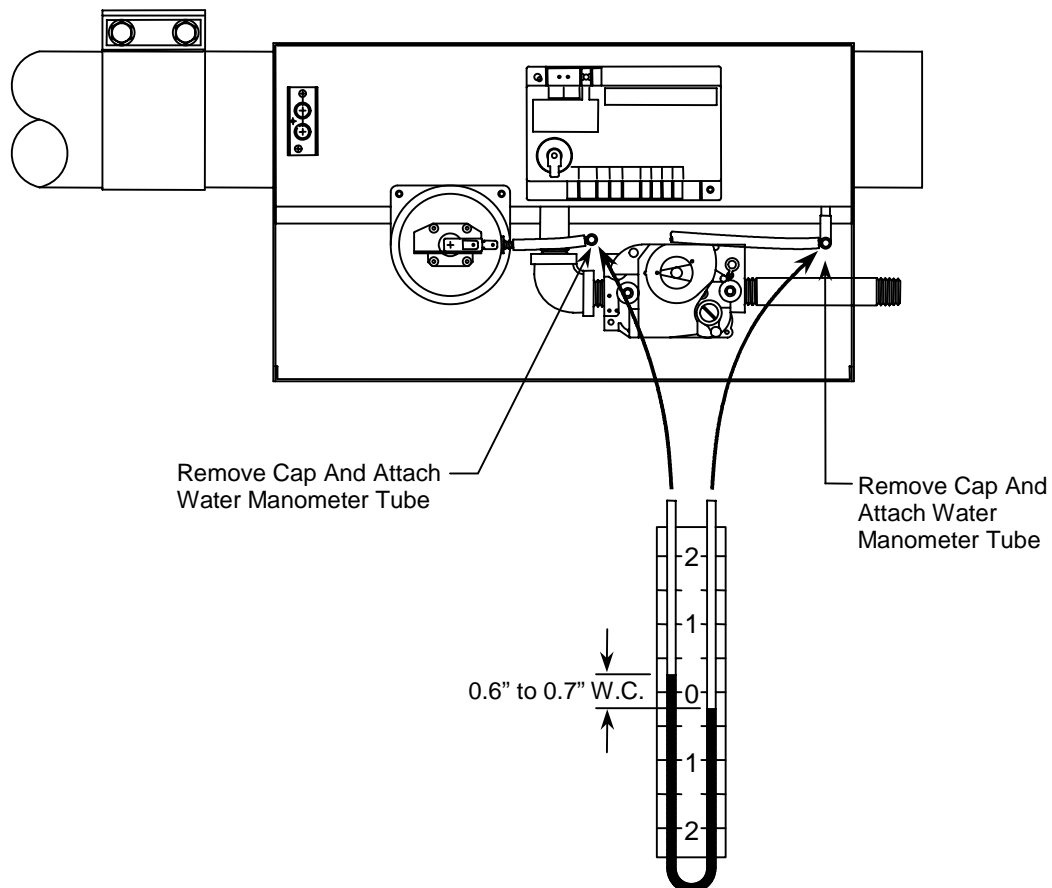

SEQUENCE OF OPERATION

1. Thermostat calls for heat.
2. Vacuum exhauster is energized.
3. Differential airflow switch proves that operation of the exhauster and the ignition control is energized.
4. After pre-purge timing, the spark igniter and gas valve are energized.
5. The ignition control senses the flame (flame rectification) and turns off the spark ignition.
6. After the thermostat is satisfied the power is removed from the burner assembly causing the ignition control, gas valve and vacuum exhauster to be de-energized.
6. System waits for the next call for heat.

OPERATION

Before connecting the system to the electric supply, check the electrical characteristics as indicated on the Rating / Nameplate to insure proper voltage and gas supply.

With the system completely assembled, all ducts attached and in full operation, measure current input to the motor and compare with the nameplate rating to determine if the motor is operating at safe load conditions and not overloaded.

GENERAL SAFETY INFORMATION

1. Follow all local electrical and safety codes, as well as the National Electrical Code (NEC) and the Occupational Safety and Health Act (OSHA).
2. Burner(s) and vacuum exhauster must be securely and adequately grounded. This can be accomplished by wiring with a grounded, metal-clad raceway system, by using a separate ground wire connected to the bare metal of vacuum exhauster frame, or other suitable means;
3. Always disconnect power source before working on or near a motor or its connected load. If the power disconnect point is out-of-sight, lock it in the open position and tag to prevent unexpected application of power.
4. Be careful when touching the exterior of an operating motor. It may be hot enough to be painful or cause burn injury. With modern motors, this condition is normal when operating at rated load and voltages. Modern motors are designed to operate at higher temperatures.
5. Protect the power cable from coming in contact with sharp objects.
6. Do not kink power cable and never allow the cable to come in contact with oil, grease, hot surfaces, or chemicals.
7. Make certain that the power source conforms to the requirements of your equipment.

8. When cleaning electrical or electronic equipment, always use an approved cleaning agent such as dry cleaning solvent.
9. Not recommended or certified as an explosion proof blower.

MAINTENANCE

WARNING: ALWAYS DISCONNECT POWER SUPPLY BEFORE SERVICING THE BLOWER OR WORKING WITH THE UNIT FOR ANY REASON. THIS IS ESPECIALLY IMPORTANT WITH UNITS EQUIPPED WITH AUTOMATIC RESET THERMAL PROTECTION. UNIT MAY ACTIVATE WITHOUT WARNING!

⚠ WARNING

FIRE OR EXPLOSION HAZARD



IMPROPER INSTALLATION, ADJUSTMENT, ALTERATION, SERVICE OR MAINTENANCE CAN CAUSE DEATH, SEVERE INJURY AND/OR PROPERTY DAMAGE.

1. Do not force the gas control knob. Use only your hand to turn the gas control knob. Never use tools.
2. If the gas control knob will not operate by hand, a qualified service technician should replace the gas control.

GAS CONTROL KNOB SETTING

The gas control knob or handle has two settings:

"OFF" prevents the main burner gas flow.

"ON" permits main burner gas flow. Under control of the thermostat and direct ignition control module, gas can flow to the main burner.

PRE-CONDITIONS TO BE CHECKED BEFORE BURNER SYSTEM STARTUP

1. System has been installed to Combustion Research Corporation recommendations in Installation Manual and nameplate data.
2. The system as installed must be installed with adequate clearance to combustibles as outlined in this manual. In storage areas where stacking of materials may occur, the installer must provide signs that specify the maximum stacking height so as to maintain the required clearance to combustibles.
3. Electrical input to each heating zone is typically a 20 to 30-amp service, 115V AC/60 HZ (1-Ph).
 - a. All main disconnects closed and fuses OK.
 - b. All service disconnect switches at each burner and exhauster turned on.

WARNING

FIRE OR EXPLOSION HAZARD



IMPROPER INSTALLATION, ADJUSTMENT, ALTERATION, SERVICE OR MAINTENANCE CAN CAUSE DEATH, SEVERE INJURY AND/OR PROPERTY DAMAGE.

It is the installer's final responsibility to verify correct gas usage.
 Do not use a gas control set for natural gas on LP Gas or a gas control set for LP Gas on Natural Gas.

4. Natural Gas Service
 - a. Meter and pipe work to be adequate size for total building requirements.
 - b. 1030 BTU/ft³ at minimum of 7" W.C. at input side of burner regulator during full operational load. (Manifold pressure is 3.5" W.C.).
5. Propane Service
 - a. Storage tanks are large enough to vaporize required maximum load and fitted with heating equipment as required by application.
 - b. Vaporizer system and high press regulators system installed as required and set at 13.5 W.C. outlet.
 - c. 2500 BTU/ft³ at minimum of 11.0" at input side of regulator on Reflect-O-Ray burner during operation. (Manifold pressure is 10.0" W.C..)
6. All gas valves in meter house and service cocks' open. All feed lines have been purged of air used at time of pipe work leakage test.
7. Exhauster has been checked for fan rotation, clockwise viewed from motor end.
8. Flex connection to fan inlet secure and free of leaks.
9. Blast damper pinned, secured, and set so that the vacuum cannot be altered.

Notes

1. Before attempting to recycle unit after a nuisance shut down: On flame failure or expiration of trial ignition, electrical supply power to burner must be interrupted for 5 minutes to allow safety switch to reset. Power can be interrupted at burner service switch or at the thermostat.
2. Do not attempt to field repair control components. It is recommended defective components be replaced as factory replacement units.

A. PRELIMINARY REQUIREMENTS PRIOR TO STARTING SYSTEM

1. The system must be installed in compliance with clearances to combustibles (see pages 5 & 6). Units installed in public garages should be in accordance with the ANSI/NFPA 88A-current standard for USA and CAN 1-B149 .or .2 for Canada. Units installed in aircraft hangars should be in accordance with

ANSI/NFPA 409-current standard for USA and enforcing authority for Canada. All reflectors should be in position and installed according to the installation instructions and Start Up section tube system of this manual.

2. Make sure gas pipes have been purged of air that might be in the pipe work. It must be adequately sized so that a minimum of 5" W.C. and maximum of 14" W.C. pressure at the burner can be obtained for natural gas and 11 " W.C. minimum, 14" W.C. maximum pressure for propane. The gas pipe work should also have been tested with soap and water at all joints as specified by local codes. It should be noted that all service cocks on individual burner should be closed prior to testing to avoid damage to the gas regulator at each burner.
3. The electrical system must be installed according to local codes and the wire must be adequately sized for the installation in accordance with the Electrical Wiring Specification in the Installation Instructions and Start-Up section of this manual. See that the fan is correctly wired so the exhauster is running in the correct direction and that none of the equipment is pulling more than the specified capacities stated in the Electrical Wiring section mentioned above.
4. The vacuum of each burner must be set by manually adjusting the damper. This is required for proper operation and performance.

B. TO START SYSTEM

1. Check to insure that main gas cock from meter is open.
2. Check all burners to insure that gas cocks at each burner are open.
3. Turn the main power switch to ON and check fuses.
4. Set the thermostat higher than the existing temperature of the area to be heated. The following steps should then take place automatically:
 - a. The vacuum exhauster is powered and will start. The vacuum created by the exhauster closes the air flow switch and supplies power to the burner, opening the gas solenoid and allowing gas into the burner chamber. The spark igniter will ignite to gas.
 - b. All three indicator lights in the burner should be on, proving the contact of the main gas valve unit, the airflow switch, and electrical power monitor (See page 33 for description and function of indicator lights).
5. Check all burners to see that they are operating. Flame should be visible through the view window and all three lights on.
6. Set the thermostat down to the desired temperature.
7. When the system is initially fired, any oil that is on the radiant tube and fittings will burn off and form a light haze in the building which can best be removed by ventilation system in the building, or opening doors. This is a one-time event and will not recur.
8. On start-up there will be condensation in system for approximately 2 minutes as fan discharge temperature gets above the condensation point. The condensation will be dried up in the pipe and discharged through the fan. This results in a slight spitting of this moisture out

of the fan discharge for approximately 4 minutes from initial start-up.

C. RESETTING THE FLAME SAFETY CONTROL

The Reflect-O-Ray burner system is equipped with an automatic lockout control, which is activated after 30 seconds if a burner should fail to ignite. If your burner should lock out, it should be reset by the follow method:

1. Turn off the toggle switch at the burner or turn down the thermostat to stop the exhauster.
2. Wait five minutes for the ignition timer switch to cool and automatically reset.
3. Turn the power back on, either by turning the toggle switch back on or turning the thermostat back up. The burner should ignite and all three indicator lights should come on.
4. The system will now automatically recycle on the thermostat to maintain desired room temperature.

IF THE BURNER WILL NOT LIGHT AFTER TWO RESET TRIALS, CONTACT YOUR INSTALLER FOR SERVICE.

D. STOPPING THE SYSTEM FOR SERVICE

1. For servicing an individual burner or exhauster, turn off the service toggle switch, which should be mounted within two feet of the unit. Close the gas supply to burners, at the individual burner gas cocks'.
2. To service the thermostat, turn off the electrical power at the main power disconnect box.
3. Before servicing any gas component; shut off the gas supply at the meter by closing the main gas valve.

BURNER INDICATOR LIGHTS

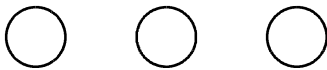

1. **DEAD MODE:** The burner power supply has been interrupted. (Trouble shooting checks: Thermostat setting, circuit breaker/fuse, power disconnect switch, loose wires)

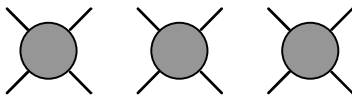

2. **START-UP MODE:** When the thermostat closes, power light energizes, airflow light energizes and burner light energizes after flame is proven.

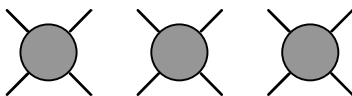

3. **NORMAL OPERATING MODE:** All three lights are on. The burner will continue to fire in the normal mode until the thermostat is satisfied.

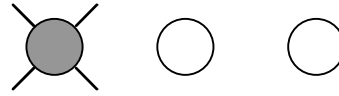

4. **AIRFLOW INTERRUPT MODE:** There is electrical power to the burner, however the air flow switch has not closed. (Trouble shooting checks: Vacuum exhauster is not running, there is an obstruction in the inlet or outlet of the system, airflow switch is defective.

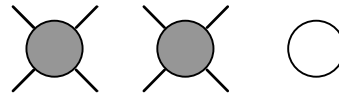

5. **LOCKOUT MODE:** After attempting to ignite for a maximum of 30 seconds, the burner ignition circuit will shut down or lockout. Reset as described above in "C".

CHECK SAFETY SHUTDOWN PERFORMANCE

NOTE: Read steps 1-7 below before starting safety shutdown or safety lockout tests for the direct ignition (DI) module.

1. Turn gas supply off.
2. Set the thermostat or controller above room temperature to call for heat.
3. Watch for ignition spark immediately or following pre-purge. See ignition module specifications.
4. Time length of ignition operation. See DI module specifications.
5. After the module locks out, open gas control and ensure there is no gas flow to main burner.
6. Set the thermostat below room temperature and wait one minute.
6. Operate system through one complete cycle to ensure all controls operate properly.

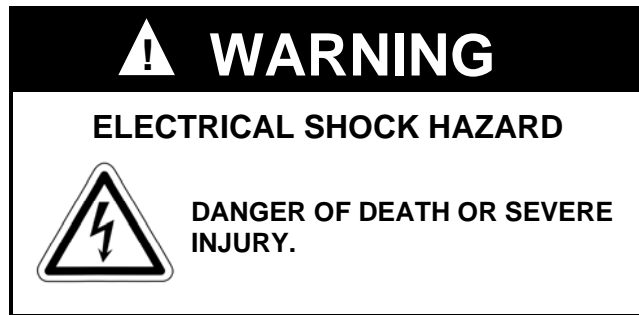

WARNING: ALWAYS DISCONNECT POWER SUPPLY BEFORE SERVICING THE BLOWER OR WORKING WITH THE UNIT FOR ANY REASON. THIS IS ESPECIALLY IMPORTANT WITH UNITS EQUIPPED WITH AUTOMATIC THERMAL RESET PROTECTION. UNIT MAY ACTIVATE WITHOUT WARNING!

GENERAL AND YEARLY MAINTENANCE:

At regular intervals or at least once a year the entire system should be inspected.

Reflect-O-Ray® EDS 4 & EHS 4 BURNER ASSEMBLY:

The gas connecting flex should be inspected for any cracks or breaks. Use a soap solution on the gas flex and gas piping to verify any leaks. **DO NOT USE OPEN FLAME FOR LEAK TEST.**

Check combustion air inlets and connecting duct work for obstructions and breakage; repair as needed.

Inspect hanging hardware, such as chains, for wear. If any wear is present, the system must not be operated until the chain(s) or associated hardware has been replaced.

Look for any deterioration in the housing assembly. Replace or repair.

Radiant Tubing:

The *Radiant Tubing* should be inspected at the beginning of every heating season. Look for cracks, holes, physical damage, etc. Replace as needed.

NOTE:

Use only approved **Reflect-O-Ray® EDS 4 & EHS 4** tube which has been specifically designed and manufactured for the **Reflect-O-Ray® EDS 4 & EHS 4** system. Use of substitute materials can result in an unsafe condition and will void any and all warranties.

DIAGNOSIS AND TESTING **Reflect-O-Ray® EDS 4 & EHS 4 BURNER ASSEMBLY:**

If the burner does not operate, a "System Check" must be made as follows:



SYSTEM CHECK

1. Check for proper installation of unit (refer to owner's manual).
2. If power is not present, check power supply to input terminals with AC voltmeter and check fuse in burner box.
3. Remove tube fitting from air switch and insert new fitting with short rubber hose attached. Normally open airflow switch can be operated with mouth vacuum to check performance. If airflow switch does not close, replace airflow switch.
4. Provided airflow switch is operating, listen for high voltage arc, an audible spark "ticking." **(DO NOT TOUCH IGNITION OUTPUT LEADS OR IGNITION ELECTRODES.)** Check to see if high voltage leaks occur at porcelains and high voltage leads.
5. If ignition arc is not present or sporadic, turn off power and check gap. It should be approximately .10 inch. **(DO NOT TRY TO MEASURE HIGH VOLTAGE OUTPUT.)** High voltage wire should not touch casing as grounding can occur when wires are wet.
6. If ignition wires and electrodes are set as above, and power is shown but no ignition arc is present, the ignition assembly is defective and the electronics should be replaced.
7. Remove gas jet, inspect for possible obstruction or incorrect orifice size.
8. Disconnect power and check terminals to be sure that there are no loose spade connections or broken wires.

ELECTRONIC PROVEN SPARK IGNITION CONTROL WITH 100% LOCKOUT:

APPLICATION

The solid state ignition control will ignite the gas by spark. The gas is ignited and burns during each running cycle.

Should a loss of flame occur, the main valve closes and a retry for ignition will commence. This control has an internal 100% lockout function to completely shut down the system should the gas fail to ignite within 30 seconds. To initiate a re-ignition trial when lockout occurs, the power must be interrupted for 5 minutes.

The solid state ignition control must not be subjected to temperatures below -40°F (-40°C) or above 150°F (66°C).

CAUTION: When it is necessary to replace a main gas valve used with this control, the replacement valve must have the same valve closing time as that approved on the original equipment by the recognized testing agency.

GAS SUPPLY FAILURE ON START

1. Thermostat calls for heat.
2. Airflow is proven.
3. Valve and spark are energized after pre-purge.
4. After a maximum 30 second trial for ignition, the system will lockout to completely disarm the system.
5. In order to initiate a re-ignition trial, the power must be interrupted for 5 minutes.

POWER INTERRUPTION ON START:

1. No gas will flow during power interruption.
2. Normal sequence will resume when power is restored.

POWER INTERRUPTION DURING RUNNING CYCLE:

1. Valve is de-energized.
2. Valve and spark are energized when power is restored and normal sequence will resume.

TURNING OFF THE APPLIANCE:

VACATION SHUTDOWN -- Set the thermostat to the desired room temperature while you are away.

COMPLETE SHUTDOWN -- Turn the gas control knob to the OFF position. Do not force. Appliance will completely shut off. Follow the Lighting Procedures above to resume normal operation.

IF MAIN BURNER WILL NOT COME ON WITH CALL FOR HEAT:

1. Ensure gas control knob is in the ON position.
2. Adjust thermostat several degrees above room temperature.
3. Using AC voltmeter, measure voltage across MV terminals at gas control.
4. If no voltage is present, check control circuit for proper operation.

4. If proper control system voltage is present, replace gas control.

STOP: READ ALL WARNINGS

The flame is lit automatically. If the appliance does not turn on when the thermostat is set several degrees above room temperature, follow these instructions:

1. Set the thermostat to its lowest setting to reset the safety control.
2. Disconnect all electric power to the appliance.
3. Remove the control access panel.
4. Turn the gas control knob to the OFF position, DO NOT FORCE.
5. Wait 5 minutes to clear out any unburned gas. If you then smell gas, STOP! Follow Step 3 in the following Warnings. If you do not smell gas, continue with the next step.

! WARNING

FIRE OR EXPLOSION HAZARD



IMPROPER INSTALLATION, ADJUSTMENT, ALTERATION, SERVICE OR MAINTENANCE CAN CAUSE DEATH, SEVERE INJURY AND/OR PROPERTY DAMAGE.

1. Flame is lit automatically. Do not light the flame manually.
2. Before lighting burner flame, smell around the appliance for gas. Be sure to smell next to floor because LP gas is heavier than air.
3. IF YOU SMELL GAS:
 - ◆ Turn off the gas supply at the appliance service valve. On LP gas systems, turn off gas supply at the gas tank.
 - ◆ Do not light any appliances in the house.
 - ◆ Do not touch electrical switches or use the phone.
 - ◆ Leave the building and use a neighbor's phone to call your gas supplier.
 - ◆ If you cannot reach your gas supplier, call the fire department.
4. Do not force the gas control knob. Use only your hand to push down or turn the gas control knob. Never use any tools. If the gas control knob will not operate by hand, a qualified service technician should replace the gas control. Force or attempted repair may result in a fire or explosion.
5. The gas control must be replaced in case of any physical damage, tampering, bent terminals, missing or broken parts, stripped threads, and evidence of exposure to heat.

6. Turn the gas control knob to the ON position.
7. Reconnect all electric power to the appliance.
8. Replace the control access pane.
9. Set the thermostat to the desired setting.
10. If the appliance does not turn on, set the gas control knob to OFF and contact a qualified service technician for assistance.

MAINTENANCE:

Regular preventive maintenance is important in applications that place a heavy load on system controls, such as in the commercial cooking and agricultural and industrial industries because:

1. In applications where the equipment operates 100,000-200,000 cycles per year. Such heavy cycling can wear out the gas control in one to two years.
6. Exposure to water, dirt, chemicals, and heat can damage the gas control and shut down the control system.

! WARNING

FIRE OR EXPLOSION HAZARD



IMPROPER INSTALLATION, ADJUSTMENT, ALTERATION, SERVICE OR MAINTENANCE CAN CAUSE DEATH, SEVERE INJURY AND/OR PROPERTY DAMAGE.

Do not disassemble the gas control. The gas control contains no replaceable components. Attempted disassembly or repair may damage the gas control.

NOTICE

Do not apply a jumper across or short the valve coil terminals. Doing so may damage the ignition module.

The maintenance program should include a regular check out of the gas control. Maintenance frequency must be determined individually for each application. Some considerations are:

1. **Cycling frequency.** Appliances that may cycle 100,000 times annually should be checked monthly.
2. **Intermittent use.** Appliances that are used seasonally should be checked before shutdown and again before the next use.
3. **Consequence of unexpected shutdown.** Where the cost of an unexpected shutdown would be high, the system should be checked more often.
4. **Dusty, wet or corrosive environment.** Since these environments can cause the gas control to deteriorate more rapidly, the system should be checked more often.

The gas control should be replaced if :

1. It does not perform properly on checkout or trouble-shooting.
2. The gas control knob is hard to turn or push down, or it fails to pop back up when released.
5. The gas control is likely to have operated for more than 200,000 cycles.

CHECKOUT PROCEDURE:

Before leaving installation, several complete operating cycles should be observed to see that all components are functioning properly.

1. Before turning on the main electrical power switch, be sure all gas supply lines are purged of air.
 2. Close main manual shutoff valve and wait for 5 minutes, then turn "A" valve to "ON" position.
- CAUTION:** Check for positive gas seal using soap solution on valve inlet and all upstream pipe connections.
3. Turn on main electrical power switch and close thermostat contacts.
 4. After the control is powered it will automatically energize the spark and the gas valve.
 5. The sensing probe detects the presence of the low fire flame and the control de-energizes the spark and the valve will remain open. Check valve outlet and other downstream pipe connections with a soap solution.
 6. Turn the thermostat to a low dial setting to open contacts. The main gas flame should be extinguished.
 7. For 100% shutoff check, set thermostat to low dial setting (system off). Disconnect sensing probe lead at control terminal.
 8. Turn thermostat to a high dial setting to energize spark ignition and valve. The gas should ignite. After 30 seconds, the system should "lockout" and burner functions are off (no gas flow, no spark). If the system does not go into "lockout," follow the installation instructions to replace the control. Repeat the 100% shutoff check. Note blower will not shut down when ignition "lockout" occurs.
 9. Set thermostat again to a low dial setting (system off), connect probe lead to control terminal. Set thermostat to normal setting to put system back in service.

**CHECK SAFETY SHUTDOWN
PERFORMANCE:**

! WARNING

FIRE OR EXPLOSION HAZARD



**IMPROPER INSTALLATION, ADJUSTMENT,
ALTERATION, SERVICE OR MAINTENANCE
CAN CAUSE DEATH, SEVERE INJURY
AND/OR PROPERTY DAMAGE.**

Perform the safety shutdown test anytime work is done
on a gas system.

NOTE: Read steps 1-7 below before starting safety shutdown or safety lockout tests for the ignition module.

1. Turn gas supply off.
2. Set the thermostat or controller above room temperature to call for heat.
3. Watch for ignition spark immediately or following pre-purge. See DI module specifications.
4. Time length of ignition operation. See DI module specifications.
5. After the module locks out, open gas control and ensure there is no gas flow to main burner.
6. Set the thermostat below room temperature and wait one minute.
7. Operate system through one complete cycle to ensure all controls operate properly.

IGNITION CHECKOUT PROCEDURES:

A combination voltmeter and micro ammeter with a DC micro ammeter range setting of 0 to 10 microampere is required. Follow meter instructions for proper use. **TO CHECK AC VOLTAGES:**

1. Set range selection switch to 150V AC before connecting leads.
2. Connect wire leads in parallel with voltage to be measured.

TROUBLE SHOOTING FLOW CHART

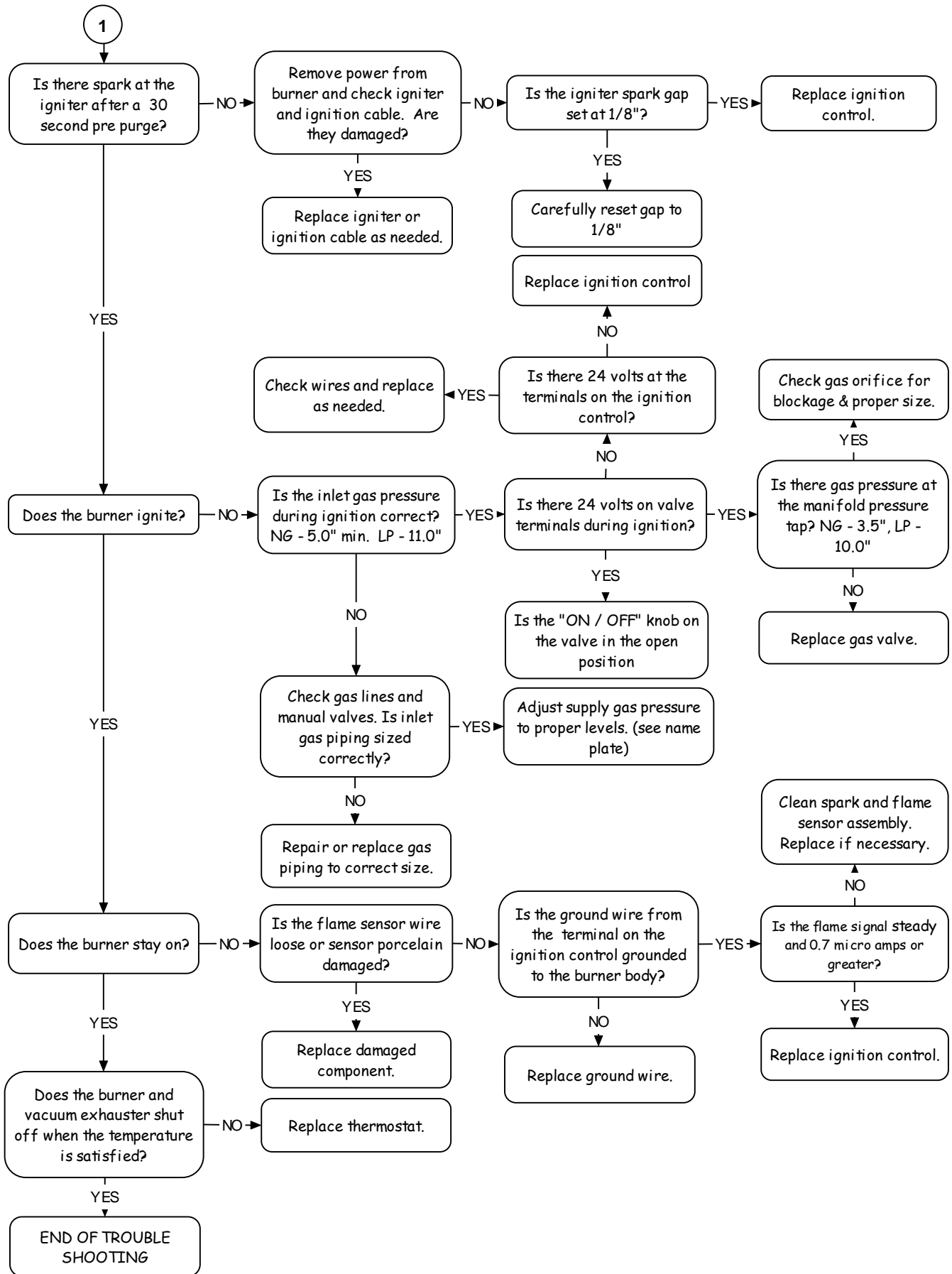

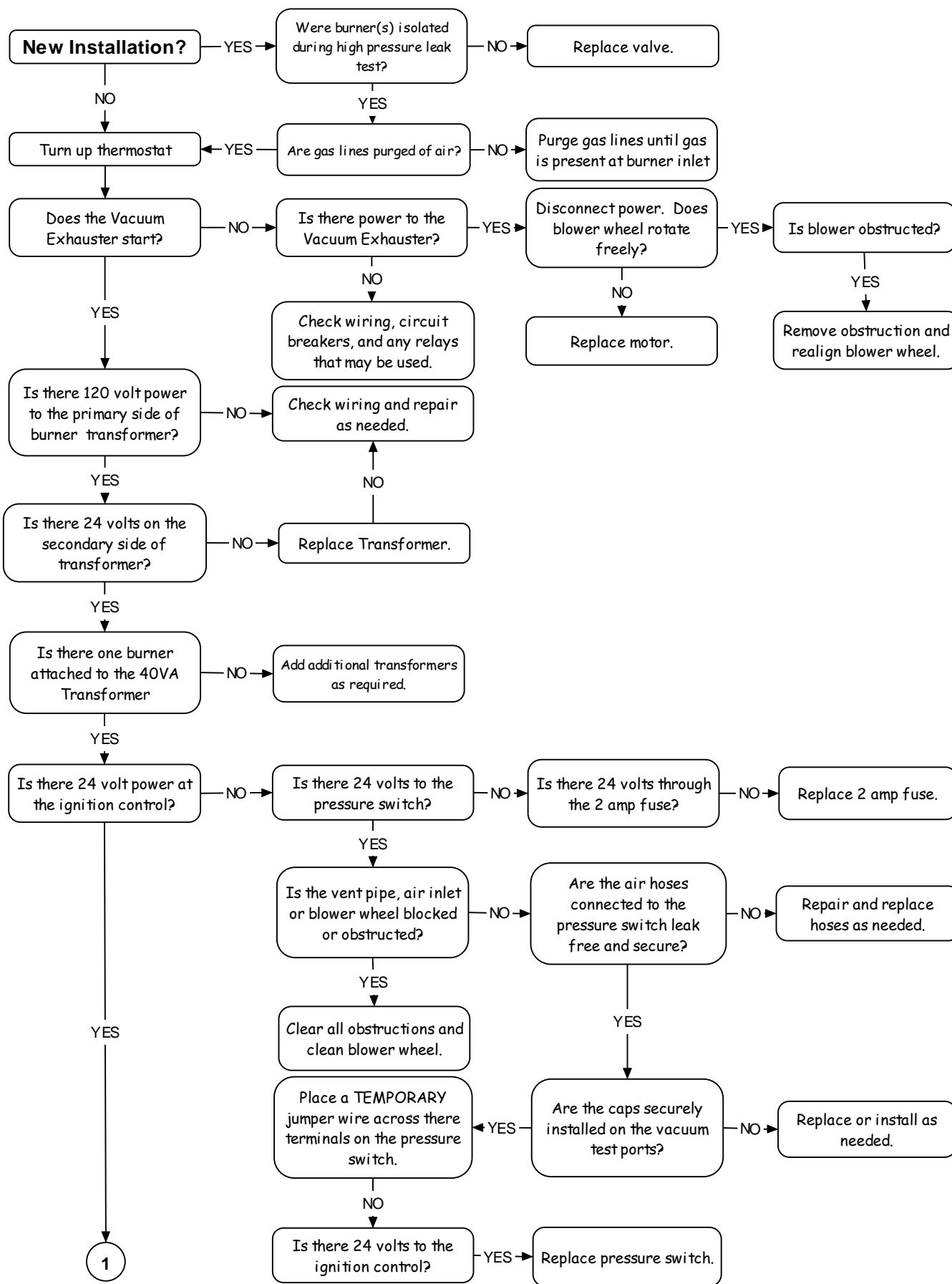

REPLACEMENT PARTS – BURNER ASSEMBLY

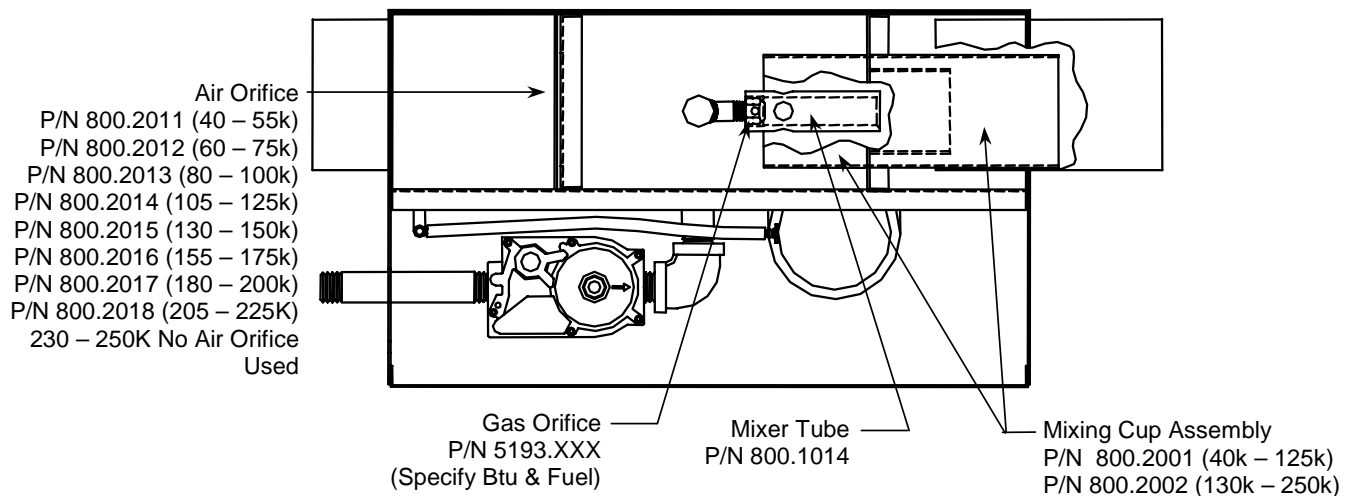
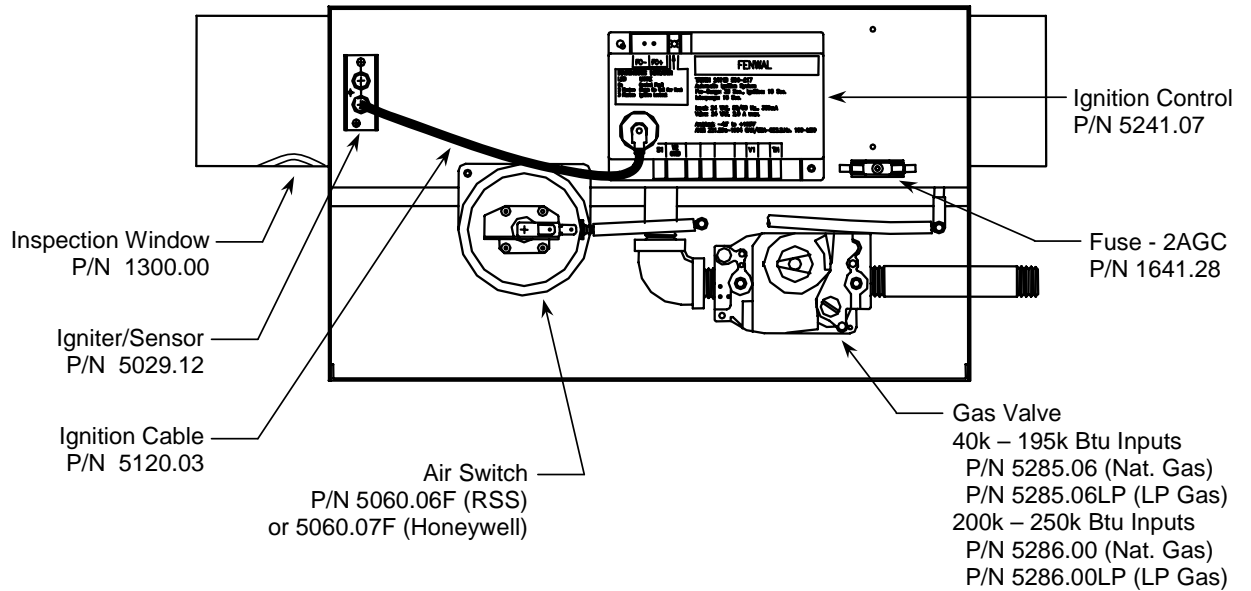

VACUUM EXHAUSTER PARTS LIST

0401.040 & 0402.040 VACUUM EXHAUSTER

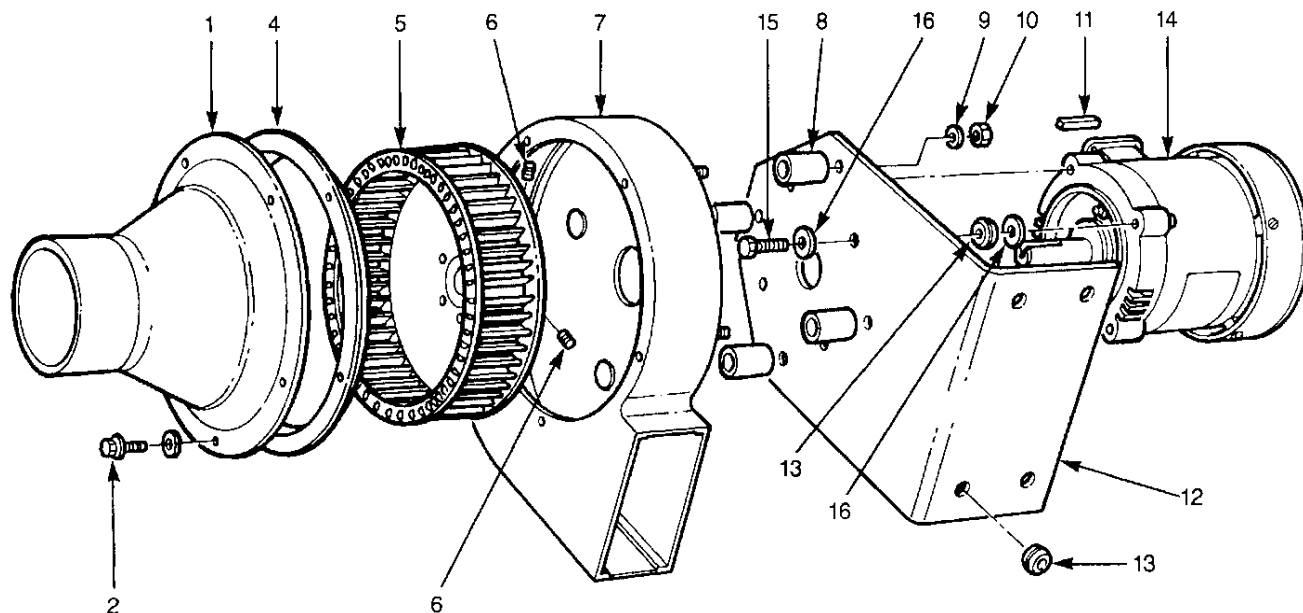

Ref No.	Part No.	Description
1	401.0704	Inlet Transition (4" System)
2	1141.05	Sheet Metal Screw
4	401.04	Venturi Plate
5	401.08	9-3/16" Diameter Exhaustor Wheel –Stainless Steel
6	1032.03	5/16" x 18 Set Screw (Provided with exhaustor wheel)
7	401.06	Vacuum Exhaustor Housing
8	1463.31.25	1/2" x 1-1/4" Stand-Off
9	1122.01	5/16" Plated Lock Washer
10	1092.00	5/16" x 18 Plated Hex Nut
11	--	3/16" Key – Provided with Motor
12	201.05	Mounting Plate
13	1491.00	Rubber Grommet
14	5321.00	1/2 HP Motor – 3450 RPM – 115v/230v, 50 Hz
	5320.00	1 HP Motor – 3450 RPM – 115v/230v, 50 Hz
15	1063.11	3/8" x 16 x1" Long Hex Bolt w/Spot Lock
16	1112.01	5/16" Plated Flat Washer

VACUUM EXHAUSTER PARTS LIST

0201.040 VACUUM EXHAUSTER

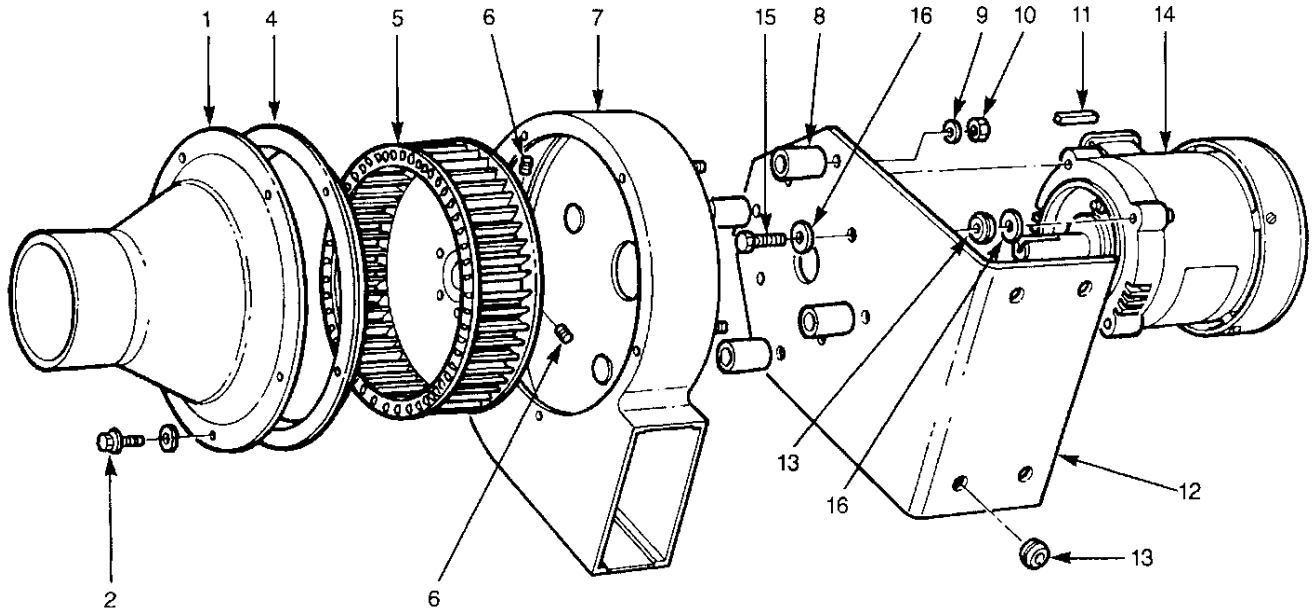

Ref No.	Part No.	Description
1	201.0704	Inlet Transition (4" System)
2	1141.05	Sheet Metal Screw
4	201.04	Venturi Plate
5	201.08	9-3/16" Diameter Exhauster Wheel –Stainless Steel
6	1032.03	5/16" x 18 Set Screw (Provided with exhauster wheel)
7	201.06	Vacuum Exhauster Housing
8	1463.31.25	1/2" x 1-1/4" Stand-Off
9	1122.01	5/16" Plated Lock Washer
10	1092.00	5/16" x 18 Plated Hex Nut
11	- -	3/16" Key – Provided with Motor
12	201.05	Mounting Plate
13	1491.00	Rubber Grommet
14	5323.00	1/4 HP Motor – 3450 RPM – 115v/230v, 50 Hz
15	1063.11	3/8" x 16 x1" Long Hex Bolt w/Spot Lock
16	1112.01	5/16" Plated Flat Washer

VACUUM EXHAUSTER PARTS LIST

0101.040 VACUUM EXHAUSTER

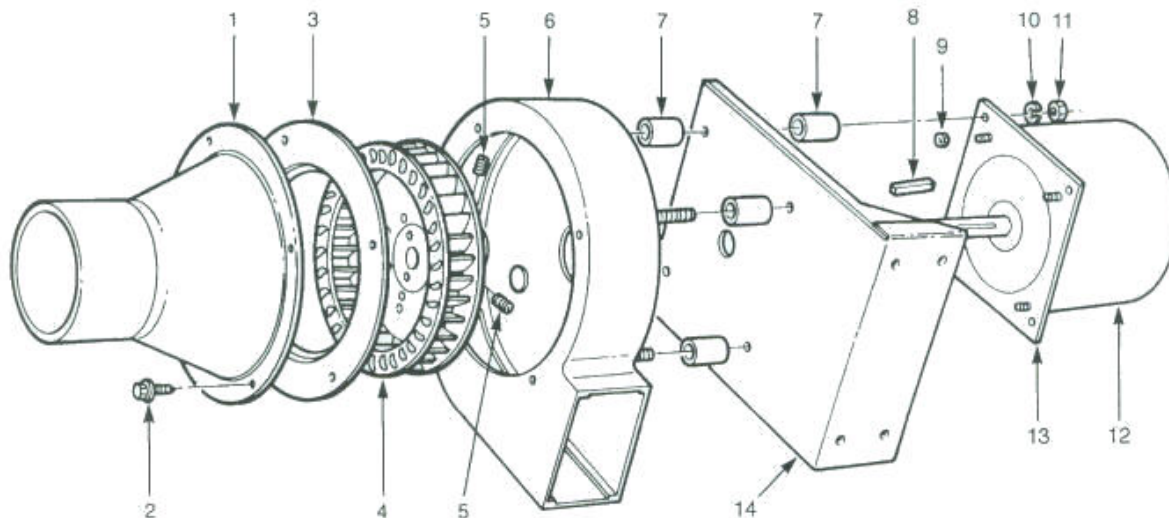

Ref No.	Part No.	Description
1	101.0704	Inlet Transition (4" System)
2	1141.05	Sheet Metal Screw
3	101.04	Venturi Plate
4	101.08	Exhaustor Wheel –Stainless Steel
5	1032.03	5/16" x 18 Set Screw (Provided with exhaustor wheel)
6	101.06	Vacuum Exhaustor Housing
7	1463.30.5	1/2" x 1/2" Long Stand-Off
8	- - -	3/16" Key – Provided with Motor
9	1088.01	8/32" Hex Keep Nut
10	1122.01	5/16" Plated Lock Washer
11	1092.00	5/16" x 18 Plated Lock Washer
12	5325.00	1/6 HP, 3450 RPM Motor
13	101.09	Motor Mounting Plate
14	101.05	Exhaustor Mounting Plate



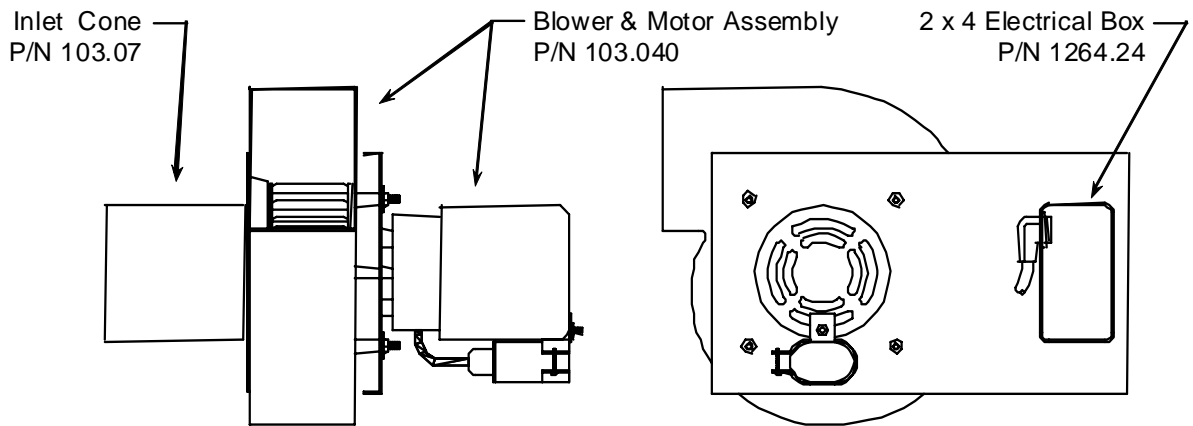



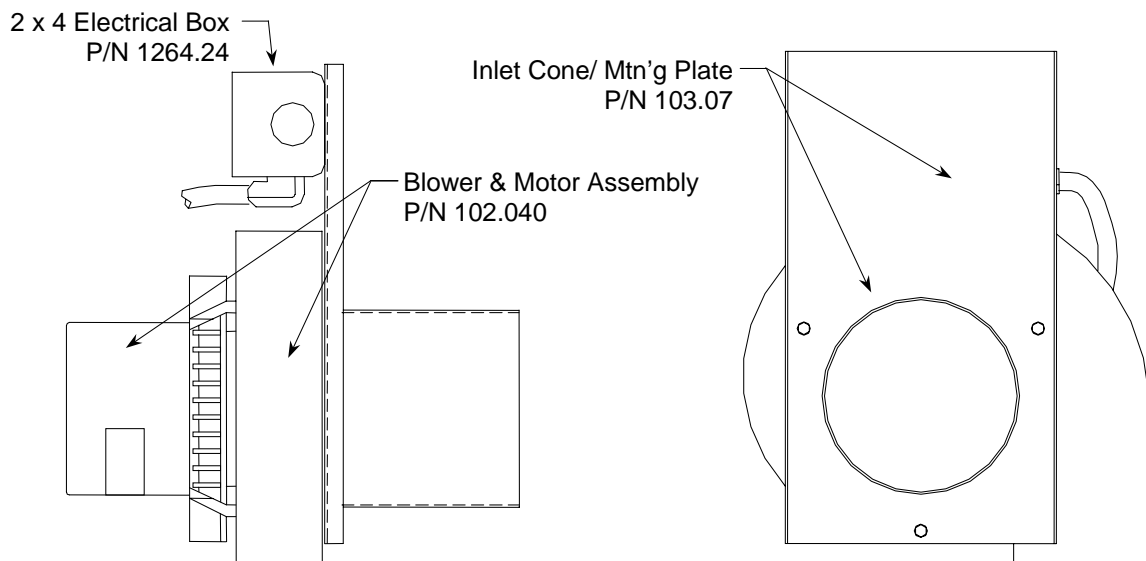

0103.040 VACUUM EXHAUSTER PARTS LIST







0102.040 VACUUM EXHAUSTER PARTS LIST

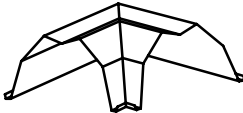

SYSTEM ACCESSORIES

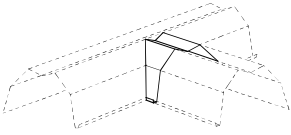
Part No.	Description	
0404.AS.16	<p>COMBUSTION TUBE Reflect-O-Tube 16 Ga. Aluminized steel combustion tube, 4" O.D., 9'-9" long. Used directly downstream of the burner for inputs up to 175K. One end swaged to fit into standard 0404.AS radiant tube.</p> <p style="text-align: right;">Wt. 80 lbs.</p>	
0404.AT.16	<p>COMBUSTION TUBE Reflect-O-Tube 16 Ga. Alumatherm steel combustion tube, 4" O.D., 10' long. Used directly downstream of the burner for inputs of 180k thru 250K. Connected to second tube, 0404.AS16, with a drawband coupler.</p> <p style="text-align: right;">Wt. 80 lbs.</p>	
0404.AS.20	<p>STANDARD RADIANT TUBE Standard Reflect-O-Tube aluminized steel. 4" O.D., 19'-6" long section of radiant tube.</p> <p style="text-align: right;">Wt. 43 lbs.</p>	
0404.AS	<p>STANDARD RADIANT TUBE Standard Reflect-O-Tube aluminized steel. 4" O.D., 19'-6" long section of radiant tube.</p> <p style="text-align: right;">Wt. 21 lbs.</p>	
0404.AS.HT	<p>STANDARD RADIANT TUBE – HEAT TREATED Standard Reflect-O-Tube heat treated aluminized steel. 4" O.D., 9'-9" long section of radiant tube.</p> <p style="text-align: right;">Wt. 21 lbs.</p>	
0363.00	<p>REFLECTOR Aluminum reflector, bright finish, 10' long – designed to direct radiant energy towards the floor area.</p> <p style="text-align: right;">Wt. 5.0 lbs.</p>	
0464.00	<p>COMBINATION HANGER Radiant tube hanger formed from 1/4" diameter zinc plated steel.</p> <p style="text-align: right;">Wt. 1 lbs.</p>	
0465.00	<p>INTERMEDIATE SUPPORT Reflector support hanger formed from 1/4" diameter zinc plated steel.</p> <p style="text-align: right;">Wt. 1 lbs.</p>	
0363.WH	<p>REFLECTOR END CAP WITH CUT OUT Aluminum reflector end cap with cut out for tube clearance.</p> <p style="text-align: right;">Wt. 0.5 lbs.</p>	
0363.EB	<p>REFLECTOR ELBOW Aluminum, bright 90° reflector elbow.</p> <p style="text-align: right;">Wt. 2 lbs.</p>	

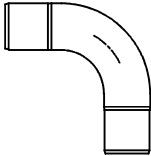
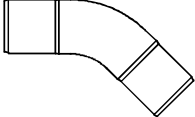
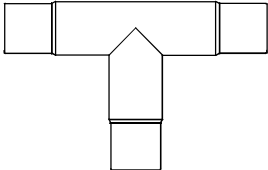

SYSTEM ACCESSORIES

Part No.	Description
0363.TB	<p>REFLECTOR TEE Aluminum, bright "TEE", requires field assembly.</p> <p style="text-align: right;">Wt. 1 lbs.</p> 
0315.AS	<p>SCREW & SEALER PAC High temperature paste sealer for all swaged radiant tube joints and self drilling and tapping screws. Use two PAC's per each burner system.</p> <p style="text-align: right;">Wt. 0.25 lbs.</p> 
0403.00	<p>DRAWBAND COUPLER Aluminized steel drawband coupler – 4" O.D. For connection of EDS6 burner assembly to combustion tube.</p> <p style="text-align: right;">Wt. 1 lbs.</p> 
0411.AS	<p>TUBE COUPLER Aluminized steel radian tube coupler. For connecting two sections of standard radian tube together. Both ends swaged to fit into 4.0" standard radiant tube.</p> <p style="text-align: right;">Wt. 1.25 lbs.</p> 
0406.AS	<p>90° ELBOW 4" DIA. Aluminized steel 90° elbow. Both ends swaged to fit into 4" standard radiant tube</p> <p style="text-align: right;">Wt. 2.25 lbs.</p> 
0436.AS	<p>45° ELBOW 4" DIA. Aluminized steel 45° elbow. Both ends swaged to fit into 4" standard radiant tube</p> <p style="text-align: right;">Wt. 2.25 lbs.</p> 
0407.AS	<p>STANDARD TEE 4" DIA. Aluminized steel "TEE". All three legs swaged to fit into 4" standard radiant tube</p> <p style="text-align: right;">Wt. 4 lbs.</p> 

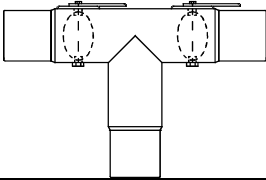
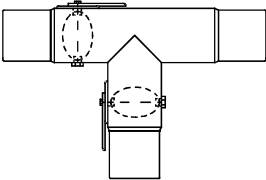
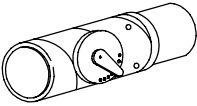
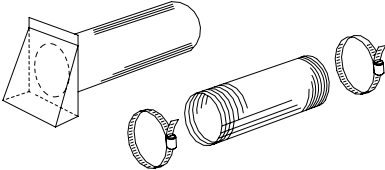
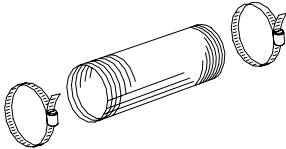
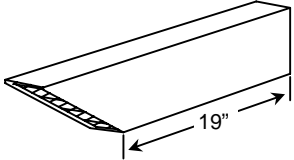
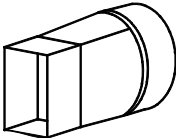
SYSTEM ACCESSORIES

Part No.	Description
0407.AS.B	<p>STANDARD TEE W/DAMPERS 4" DIA. Aluminized steel "TEE" with dampers in line. All three legs swaged to fit into 4" standard radiant tube</p> <p style="text-align: right;">Wt. 5 lbs.</p> 
0407.AS.C	<p>STANDARD TEE W/DAMPERS 4" DIA. Aluminized steel "TEE" with dampers at 90°. All three legs swaged to fit into 4" standard radiant tube</p> <p style="text-align: right;">Wt. 5 lbs.</p> 
0441.00	<p>DAMPER ASSEMBLY Damper assembly mounted in 8" long, 4" dia. aluminized steel radiant tube section with a 0411.AS coupler included.</p> <p style="text-align: right;">Wt. 3 lbs.</p> 
0414.00	<p>AIR INLET AND FLEX TUBE ASSEMBLY Weather proof air inlet with bird screen – 4" OD, 12" long with 4" OD flex 24" long and two hose clamps.</p> <p style="text-align: right;">Wt. 2 lbs.</p> 
0434.SS	<p>STAINLESS STEEL EXHAUST FLEX AND CLAMPS 4" ID high temperature stainless steel flex with a black fiberglass wrap, 30" long and two hose clamps.</p> <p style="text-align: right;">Wt. 2 lbs.</p> 
0419.00	<p>EXHAUST DUCT Side wall exhaust duct for use with 0401.040 and 0402.040 vacuum exhauster. Aluminized steel construction with stainless steel bird screen, powder coated.</p> <p style="text-align: right;">Wt. 6 lbs.</p> 
0420.01	<p>RECTANGULAR TO ROUND EXHAUST ADAPTER Adapter for connection to vacuum exhauster to accommodate connection to 6.0" dia. Round vent pipe.</p> <p style="text-align: right;">Wt. 1 lbs.</p> 

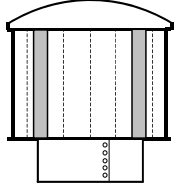
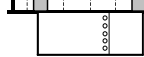
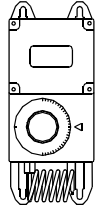
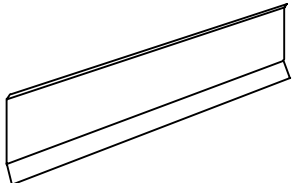
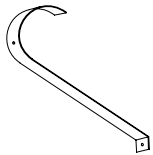
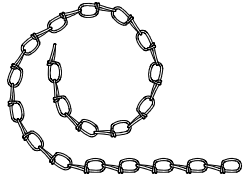
SYSTEM ACCESSORIES

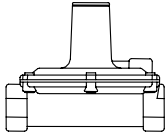
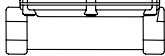
Part No.	Description	
1811.VT.400	ROOF OR WALL VENT Round, 4" dia. high wind vent cap. Connects to "B" vent Wt. 2.0 lbs.	
1811.VT.600	ROOF OR WALL VENT Round, 4" dia. high wind vent cap. Connects to "B" vent Wt. 1.5 lbs	
5487.00	THERMOSTAT Line voltage, moisture proof, 40°F to 110°F NEMA 4X enclosure – 16 FLA Wt. 1.5 lbs.	
0366.00	SIDE SHIELD - Aluminum side shield. Used on 0363.00 reflector, 10' long. Wt. 4.0 lbs.	
0366.0050	SIDE SHIELD HANGER – Side shield support. Used on 0366.00 side reflector. Wt. 1 lb.	
1800.CH.100	HANGING CHAIN Double loop, zinc plated hanging chain, 100' – work load rating of 90 lbs. Wt. 6.5 lbs.	
1800.SH.000	"S" HOOKS Box of 50, zinc plated "S" hooks. Wt. 2 lbs.	
5221.00	HIGH PRESSURE REGULATOR - For Natural gas, 5 lbs. to 7.0" W.C., ½" NPT Wt. 1.0 lbs.	
5221.04	HIGH PRESSURE REGULATOR - For Natural gas, 5 lbs. to 7.0" W.C., ¾" NPT Wt. 2.0 lbs.	

- NOTES -

WARRANTY STATEMENT

Combustion Research Corporation ("CRC") offers the end-use buyers of its products a specific and limited three-year standard Warranty covering the Reflect-O-Ray® product systems or components, the details of which are given below. This Warranty is offered only to the Buyer-For-End-Use ("Buyer") and becomes effective when the product is properly installed and maintained. Proper installation shall be assumed (for purposes of this warranty only) if installation is performed by a qualified installer in accordance with the owners manual as well as local, state and federal standards.

In addition, to the three-year warranty on all product components, Combustion Research Corporation also offers the Buyer an Extended Warranty on the radiant heater tubing (Infrared Emitter), which is installed as original equipment with a Combustion Research Corporation infrared radiant energy heating system. This Extended Warranty becomes effective (1) on the invoice date of the original equipment from CRC, and (2) the product is properly installed and maintained in accordance with the owners manual

This Warranty is subject to limitations and conditions which effect the Buyer's rights and which can lead to voidance of the warranty. The Buyer should read and understand these limitations.

DISCLAIMER OF IMPLIED WARRANTIES

(Please Read Carefully)

COMBUSTION RESEARCH CORPORATION ("CRC") DISCLAIMS ANY AND ALL IMPLIED WARRANTIES OF ANY KIND OR DESCRIPTION, INCLUDING WITHOUT LIMITATION WARRANTIES OF MERCHANTABILITY, FITNESS FOR A PARTICULAR PURPOSE, CONDITION, QUALITY OR DURABILITY, WHICH MAY BE PROVIDED BY LAW AS RELATES TO ALL PRODUCTS MANUFACTURED, SOLD, ASSEMBLED AND/OR PROVIDED TO THE ULTIMATE USER, TRANSFEREE, CONTRACTOR, CONSUMER, BUYER AND/OR PERSON UNDER THE LAWS OF THE STATE OF MICHIGAN AND/OR THE UNIFORM COMMERCIAL CODE. THIS DISCLAIMER MEANS NO IMPLIED WARRANTY OF ANY NATURE WHATSOEVER DEALING WITH THE ULTIMATE USE OF THE PRODUCT ASSEMBLED, MANUFACTURED AND/OR SOLD BY CRC SHALL BE GRANTED TO ANY PARTY WHO WITHOUT SAID DISCLAIMER WOULD BE ENTITLED TO BRING AN APPROPRIATE ACTION IN THE COURTS OF THE STATE OF MICHIGAN AS THE LAW SO PROVIDES. THE EXPRESS WRITTEN WARRANTY OF CRC FOR EACH PARTICULAR TRANSACTION SHALL BE THE ONLY EXPRESS WARRANTIES SO PROVIDED AND SHALL BE THE ONLY WARRANTY PROVIDED BY CRC FOR ITS PRODUCTS. THERE ARE NO WARRANTIES WHATSOEVER BEYOND THE DESCRIPTION ON THE FACE HEREOF.

DISCLAIMER OF DAMAGES

(Please Read Carefully)

IN NO EVENT SHALL CRC BE LIABLE FOR SPECIAL, INDIRECT, CONSEQUENTIAL OR INCIDENTAL DAMAGES OF ANY TYPE OR DESCRIPTION WHETHER ARISING UNDER CONTRACT, WARRANTY, TORT, NEGLIGENCE, STRICT LIABILITY OR ANY OTHER THEORY OF LIABILITY. SUCH DAMAGES INCLUDE, BUT ARE NOT LIMITED TO, LOSS OF PROFITS, LOSS OF USE OF THE PRODUCTS, DAMAGE TO PROPERTY, INCONVENIENCE AND CLAIMS OF THIRD PARTIES. SOME STATES DO NOT ALLOW THE EXCLUSION OR LIMITATION OF INCIDENTAL OR CONSEQUENTIAL DAMAGES, OR ANY LIMITATION OF INCIDENTAL OR CONSEQUENTIAL DAMAGES OR ANY LIMITATIONS ON HOW LONG AN IMPLIED WARRANTY LASTS, SO THE ABOVE EXCLUSION OR LIMITATION MAY NOT APPLY TO YOU. THIS WARRANTY GIVES YOU SPECIFIC LEGAL RIGHTS WHICH VARY FROM STATE TO STATE. HOWEVER, TO THE EXTENT PROVIDED BY LAW, MICHIGAN LAW CONTROLS ALL RIGHTS AND OBLIGATIONS HEREUNDER.

LIMITATIONS AND CONDITIONS FOR STANDARD WARRANTY.

The express written Warranty is a representation by CRC that the products, including all components, purchased by the Buyer from CRC or an authorized CRC representative are free from defects in material and workmanship. This Warranty applies to defects which are discovered either upon receipt of the product, or up to three (3) years after receipt of the product or CRC's invoice date, whichever event last occurs. If any such defect is found and the Buyer has satisfied the warranty requirement, and the warranty is not voided under any of the following conditions, CRC will replace free-of-charge, the defective part or parts. However it is not CRC's obligation to find, remove, or transport the defective part or parts. Further, it is not CRC's obligation to install or to pay for installation of any replacement part or parts. Repair or replacement of defective part or parts will only be done after CRC has determined in its sole judgment that the warranty applies.

LIMITATIONS AND CONDITIONS FOR EXTENDED 10 YEAR WARRANTY

The Extended Warranty is a special offer made by Combustion Research Corporation (CRC) to Buyers-For-End-use of CRC products to give them an extra term of replacement part protection. The Extended Warranty covers the infrared emitter tubing. The infrared tubing is guaranteed by CRC against internally created rust through corrosion (which is caused by the condensation of products of combustion inside the emitter tube when the flue gas temperature is allowed to fall below the dew/condensation point) for 10 years from CRC's invoice date. If any defect is found during this period, and if the Buyer-For-End-Use has satisfied the Warranty and Extended Warranty requirements, and if the warranty is not voided under any of the following conditions, CRC's obligation is either repair the defective part or to furnish the Buyer-For-End-Use with a

replacement part or parts. As with the Standard Warranty, it is not CRC's obligation to find, remove or transport the defective part or parts, or to pay for finding, removing, or transporting such part or parts, and it is not CRC's obligation to install or pay for installation of the replacement part or parts. Again, it is the Buyer's obligation to send the part or parts freight pre-paid to CRC.

LIMITATIONS ON STANDARD AND EXTENDED 10 YEAR WARRANTY

These Warranties are the only warranties offered by Combustion Research Corporation (CRC) and are in lieu of all other warranties either express or implied. CRC shall not be liable for any special, incidental or consequential damage, such as damage to a building or persons or things within a building due to any kind of radiant energy heating system failure. In addition, the Standard and Extended Warranties apply only to those products which are shipped to and installed in the United States & Canada.

ARBITRATION

In the event any Buyer, user, subsequent owner, transferee, installer, purchaser and/or ultimate customer experiences any problem, difficulty and/or has a complaint dealing with the use, installation and/or operation of the products sold, delivered and/or manufactured by CRC under the terms and provisions of any purchase order, contract, invoice or other document, then the differences between that person or entity and CRC shall be amicably resolved. In the event a resolution of the differences between the parties is unable to be accomplished, said matter shall be resolved through final and binding arbitration under the laws of the State of Michigan. The party complaining shall select, appoint and pay for an arbitrator. CRC shall select, appoint and pay for an arbitrator, and the two (2) arbitrators so selected shall agree upon and appoint a third impartial arbitrator. The dispute and/or matter of controversy shall be submitted to the arbitrators who by majority vote shall render a final and binding decision dealing with the controversy in existence between the parties. Said decision shall be enforceable in a Michigan Court maintaining jurisdiction over said matter under the requisite provisions of Michigan law. The costs of the impartial arbitrator shall be paid one-half (1/2) by the complaining party and one-half (1/2) by CRC.

MICHIGAN LAW TO GOVERN

This contract and/or document dealing with the purchase sale and/or installation of products sold and/or manufactured by CRC shall be governed by the laws of the State of Michigan, both as to its interpretation and performance. The place of this contract, its situs and forum shall at all times be the State of Michigan. All matters relating to the validity, construction and enforcement of this contract shall be determined in the appropriate courts maintaining jurisdiction over all controversies in the State of Michigan.

VOIDING OF WARRANTIES

Each of the following listed events, conditions, acts or omissions by any person or entity may void the Warranty:

1. Improper installation; i.e., installation which is not in accordance with the instructions in the service and installation manual.
2. Running the burner(s) with intake combustion air drawn from an atmosphere which is contaminated with halogenated hydrocarbons, fluorocarbons, or other corrosive substances.
3. Relocation or reinstallation of the product or system.
4. Use of electrical power having voltages, frequencies or transients which exceed product or system ratings.
5. Physical abuse or neglect to the product system or components of the system; i.e., allowing the product system to operate with broken or damaged system components.
6. Damage to the product system or components of the product system by fire, flood, earthquake or act of God.
7. Removal of the serial number or nameplate.
8. Refusal to permit inspection and/or service of the product system or parts by an authorized CRC representative.
9. Repair or replacement of any product components or other heating components which have been repaired or replaced with other than factory parts.
10. Designing or allowing the system to run with a "short cycle" or continuous condensing mode; i.e., using low voltage temperature controls without a minimum eight (8) minute run time which would allow the startup condensate to collect in the tubing system.

The determination and evaluation of any or all of the above conditions shall be according to the sole and exclusive discretion of CRC, and/or its authorized representative. If, upon examination, either CRC or its authorized representative determines that the defect or defects are caused by any of the above, the warranty obligation of CRC shall not be honored. No representative of CRC, other than an officer, has authority to change or extend these provisions or warranties. Changes or extensions shall be binding only if confirmed in writing by CRC's duly authorized executive officers. Product systems installed by CRC or its authorized representatives shall be or presumed to be properly installed and to be free of any and all conditions which might void the warranty at the time of installation. All product components or systems repaired or replaced are warranted under the same terms and conditions as the original Warranty, but only for the remaining time under the original warranty. No action shall be brought for any breach of this warranty more than one (1) year after the cause of action for such breach arises. Nothing herein shall be construed to extend any warranty beyond the stated periods. CRC shall not be liable for any default or delay in performance by it in accordance with these warranties which delay or performance is caused by contingency beyond its control including but not limited to war, government restriction or restraint, strikes, fire, floods, unavailability of raw material, and acts of God.